

NOTES

- 1) ALL DIMENSIONS ARE GIVEN IN INCHES UNLESS OTHERWISE SPECIFIED.
- 2) DESIGN CONDITIONS:  
35 GPM @ 100 PSI  
MAX TEMP 100 °F  
FLOODED SUCTION REQUIRED
- 3) BACKWASH FLOWRATE: 25-35 GPM
- 4) APPROXIMATE MASS:  
SYSTEM: 367 LBS  
OPERATING: 711 LBS

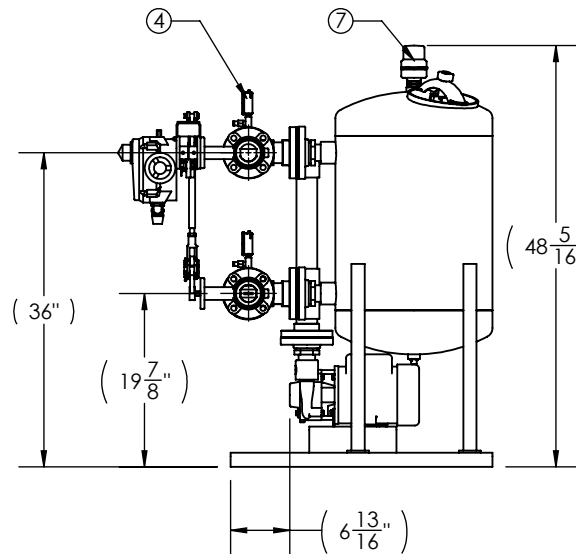
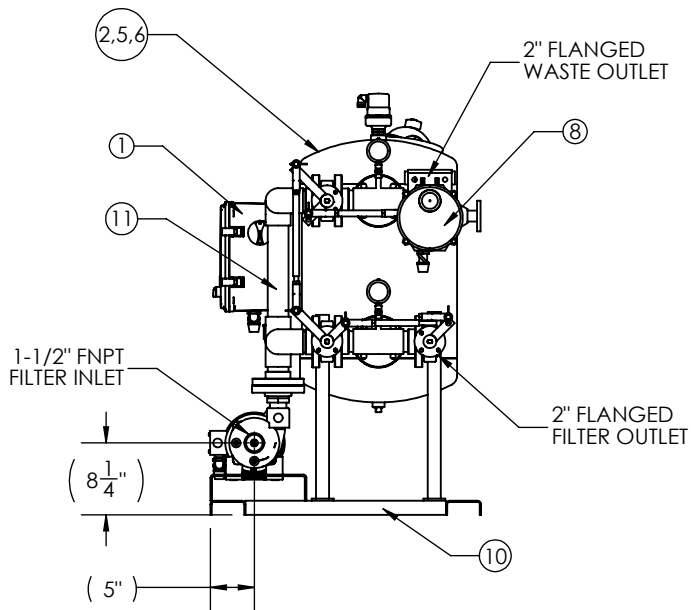

#	COMPONENT
1	NEMA 4X, UL, 460V/3PH/60Hz CONTROL PANEL, FLA=1.45A
2	MEDIA TANK: 18" 304 SS
3	PUMP: 1HP 3600RPM, 460/3/60, 35 GPM @ 50' TDH
4	INLET/OUTLET PRESSURE GAUGES: 2.5" 0-100 PSI, LIQ FILLED
5	MEDIA: UNIGRAN #50 (X2), UNIGRAN #475 (X2)
6	UNDERDRAIN/OVERDRAIN: SLOTTED PVC/ SCH 80 PVC
7	AIR RELIEF VALVE: BARAK 1" NPT
8	ELECTRIC VALVE ACTUATOR: BRAY S70-0600
9	FILTER VALVES: BRAY S-31, BUTTERFLY, EPDM SEATS
10	BASE: 304 SS C-CHANNEL
11	FACE PIPE: 2" PVC SCH 80

**amiad**<sup>®</sup> WATER SYSTEMS  
 120-J TALBERT ROAD  
 MOORESVILLE, NC 28117  
 PH: (704) 662-3133  
 FAX: (704) 662-3155

THIS DRAWING, AND THE INFORMATION CONTAINED HEREIN, IS THE PROPERTY OF AMIAD WATER SYSTEMS. ANY USE OR REPRODUCTION THEREOF WITHOUT THE WRITTEN PERMISSION OF AMIAD WATER SYSTEMS ENGINEERING DEPARTMENT IS STRICTLY PROHIBITED.

DRAWING DATE: 2/22/2016	DRAWING TITLE: HMF3-18 SS TANK WITH FACE PIPING AND PUMP
SCALE: 1:22	DRAWING NUMBER: <b>210290-000002</b>
SHEET 1 OF 3	CAT NUMBER: 210290-000002
DRAWN BY: BJH	REV. NO. 0
CHECKED BY: _____	GENERAL TOLERANCES (EXCEPT AS NOTED)
APPROVED BY: _____	ANGULAR ± 1° FRACTIONAL ± 1/8" Dec: 2 PL ± 0.05", 3 PL ± 0.010"

NO.	REVISION NOTES	DATE	BY
5			
4			
3			
2			
1			

460V/3 $\phi$ /60 Hz

L1 L2 L3

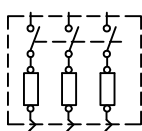

MAIN DISCONNECT AND BRANCH CIRCUIT PROTECTION PROVIDED BY OTHERS (MAXIMUM OF 10A DUAL TIME DELAY FUSE OR 14A INVERSE TIME BREAKER RECOMMENDED)

150VA TRANSFORMER		
Voltage	Fuse	Location
460	1A	H1-H4
230	2A	H2-H4
208	2A	H3-H4

LOCKABLE NON-FUSED DISCONNECT SWITCH (RATED @ 16 AMPS)

ALL PRIMARY FUSING TO BE LITTELFUSE CLASS CC, CCMR OR EQUIV.

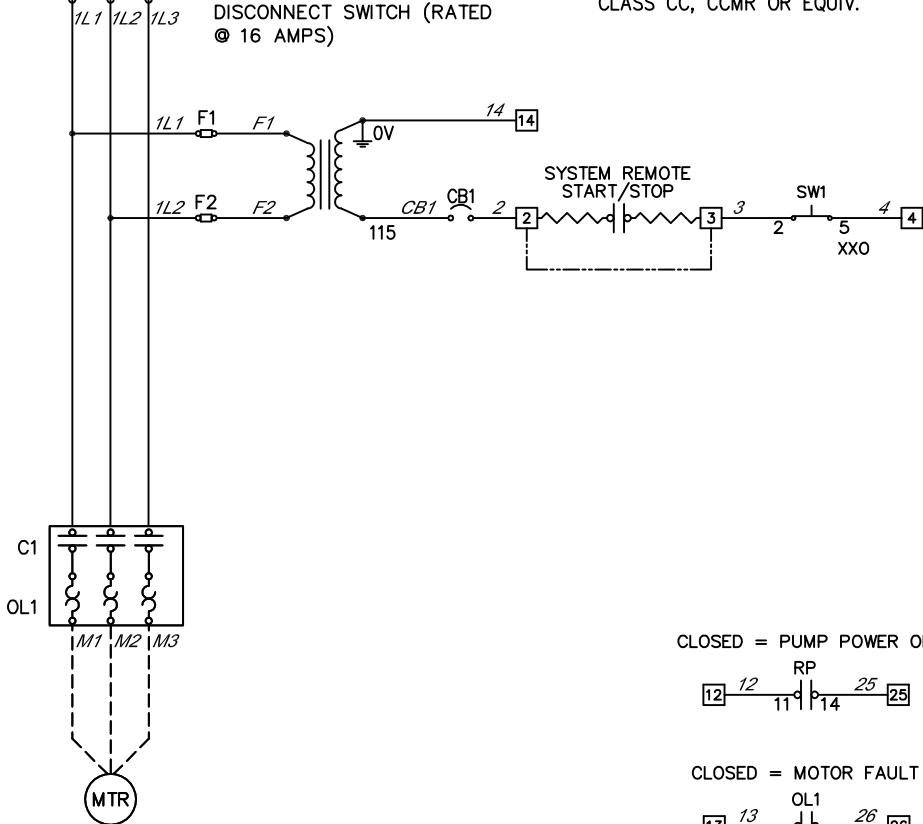

CLOSED = PUMP POWER ON

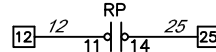

CLOSED = MOTOR FAULT

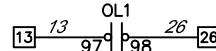

MAX. VOLTAGE: 600V  
MAX. AMPERES: 5A

POWER	POWER	460V/3~ /60HZ
	TOTAL FLA	5.33 AMPS
	SCCR	5 kA RMS SYMMETRICAL, 600V MAX.
	LARGEST MTR.	3 HP

STANDARD	UL 508A
SIZE	12"L x 10"W x 6"D
UL RATING	TYPE 4X
MATERIAL	POLYCARBONATE

- GROUND PER 2011 NATIONAL ELECTRICAL CODE ARTICLE 250.
- PANEL WIRING:  
SHOP/FIELD WIRING: \_\_\_\_\_  
CUSTOMER'S WIRING: \_\_\_\_\_  
FACTORY INSTALLED JUMPER: \_\_\_\_\_
- USE COPPER WIRE RATED 60°C MINIMUM UNLESS OTHERWISE SPECIFIED.
- DISCONNECT SWITCH TORQUE REQUIREMENTS: 35 LB IN. CONTACTOR/OVERLOAD TORQUE REQUIREMENTS: 7-10 LB IN.
- SIZE THE MAIN DISCONNECT AND BRANCH CIRCUIT PROTECTION PER 2011 NATIONAL ELECTRIC CODE ARTICLE 430.

- CONDUIT HUBS AND FITTINGS MUST HAVE THE SAME UL ENVIRONMENTAL RATING AS THE CONTROL PANEL ENCLOSURE.
- WIRE COLORS ARE AS FOLLOWS—LINE=BLACK, AC=RED, NEUTRAL=WHITE, DC+=BLUE, DC-=WHITE/BLUE, GROUND=GREEN/YELLOW, EXTERNAL SOURCE=YELLOW.
- SET MOTOR OVERLOADS ACCORDING FLA ON MOTOR DATA PLATE
- ALL MOTOR WIRING TO BE AT LEAST CU, 75° RATED.
- TB1= [5] TBA= (1) TBB= (1)

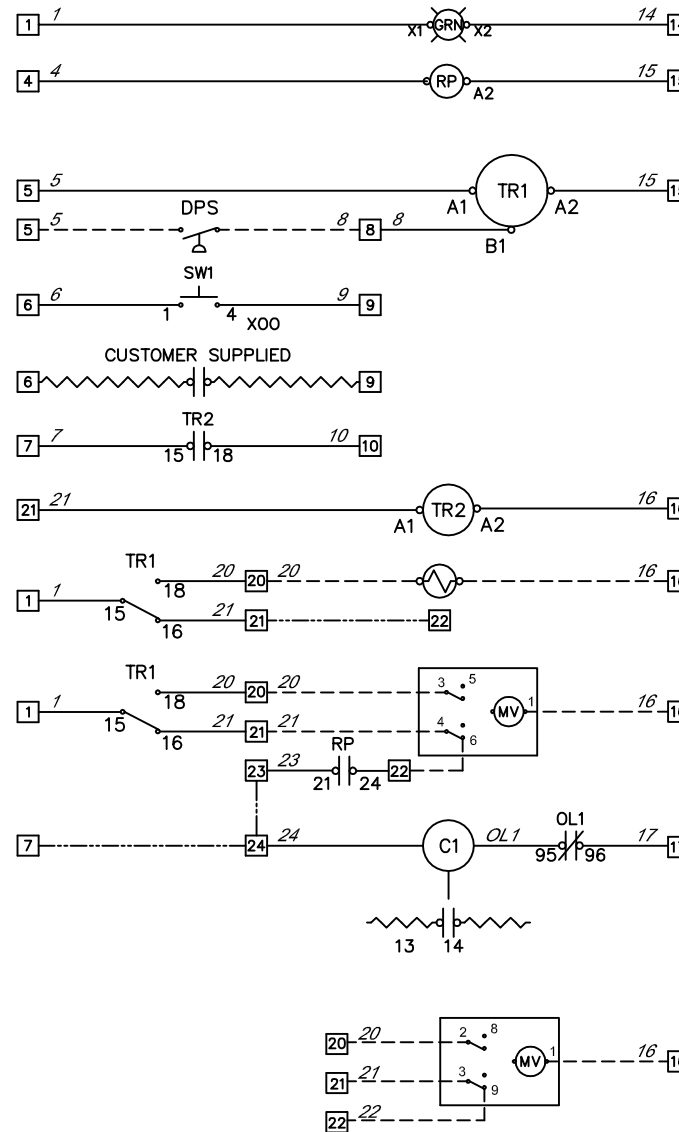

- POWER ON LIGHT
- PUMP POWER ON
- FLUSH DURATION (2 MIN) DIFFERENTIAL PRESSURE
- LOCAL FLUSH START
- REMOTE FLUSH START
- CYCLE TIMER
- CYCLE TIMER (0.05S-60HRS)
- FLUSH VALVE OPTIONS (SHOP TO ADD JUMPER FROM TB21 TO TB22 IF SOLENOID FLUSH VALVE IS USED)
- SYSTEM PUMP (REMOVE JUMPER FROM TB7 TO TB24 FOR EXTERNAL SOURCE FLUSH; REMOVE MECHANICAL JUMPER FROM TB23 TO TB24 FOR SYSTEM FLUSH)

OPTIONAL BRAY ACTUATOR

**Amiad**® WATER SYSTEMS 120-J TALBERT ROAD MOORESVILLE, NC 28117 USA (704) 662-3133 FAX (704) 662-3155

THIS DRAWING AND THE INFORMATION CONTAINED HEREIN IS THE PROPERTY OF AMIAD WATER SYSTEMS. ANY USE OR REPRODUCTION THEREOF WITHOUT THE WRITTEN PERMISSION OF AMIAD WATER SYSTEMS ENGINEERING DEPARTMENT IS STRICTLY PROHIBITED.	
5 10/10/2017 REMOVE COUNTER	RAM DRAWING DATE: 05/09/2014
4 07/25/2016 ADD COUNTER, FIX PUMP "SOURCE" POWER	RAM
3 02/25/2016 ADD BRAY ACTUATOR OPTION	RAM SCALE: 1" = 1"
2 07/09/2014 MOTOR CONTROL	CEH SHT. 1 of 2
1 06/03/2014 WIRE LABELS	JTE DRAWN BY: JTE
NO. DATE NOTES	BY CHKD BY: SAL
GENERAL REVISIONS	
APP. BY: _____	
DRAWING TITLE: 1F 460V/3~ UNI/SOL PEP 1-3.19A WIRING DIAGRAM	
DRAWING NUMBER: 720102-002073-ELC REV. NO. 5	
CATALOG NUMBER: 720102-002073	
GENERAL TOLERANCES (EXCEPT AS NOTED) ANGULAR ±1° FRACTIONAL ± 1/8" DEC: 2PL±0.05", 3PL±0.010"	

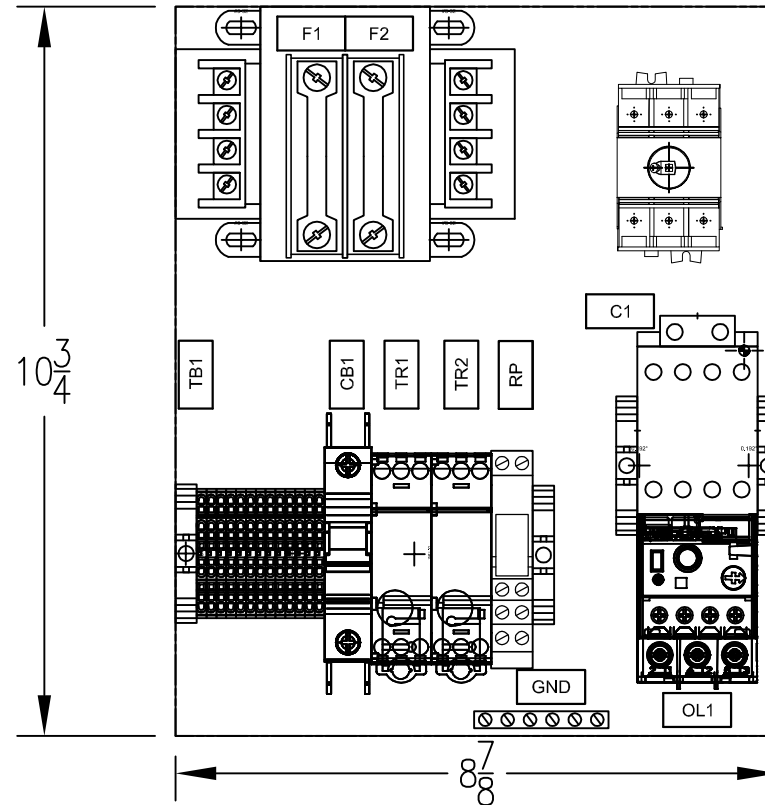
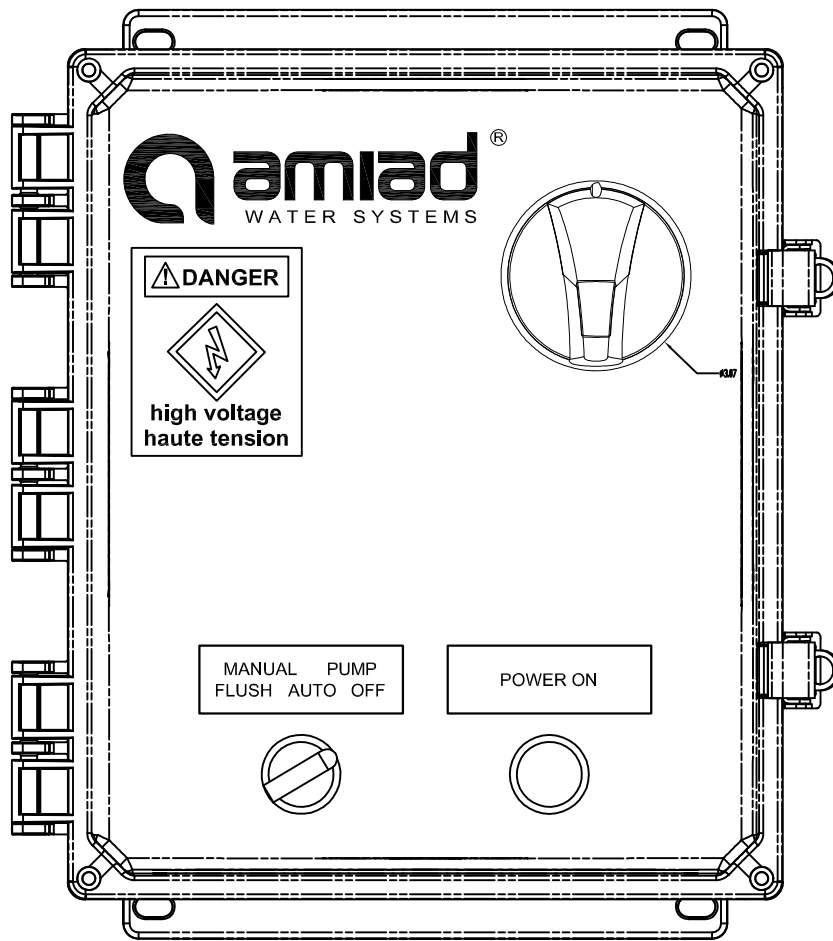

UPPER LEVEL

1	2	3	4	5	6	7	8	9	10	11	12	13
---	---	---	---	---	---	---	---	---	----	----	----	----

LOWER LEVEL

14	15	16	17	18	19	20	21	22	23	24	25	26
----	----	----	----	----	----	----	----	----	----	----	----	----

**NOTE**

- ALL HARDWARE WILL INCLUDE ONE MECHANICAL LOCK AND A FLAT WASHER.
- THE ONLY EXCEPTION IS IF THE MECHANICAL SCREW IS A SELF-THREADING SCREW.
- IF BOLT/SCREW NEEDS TO GO THROUGH A THROUGH-HOLE, THE BOLT/SCREW WILL NEED A FLAT WASHER ON BOTH SIDES OF THE MATERIAL AND MECHANICAL LOCK BEFORE THE NUT.
- ALL HARDWARE HAS TO THREAD AT LEAST TWO COMPLETE TURNS THROUGH THE NUT/THREADED HOLE
- IF VISIBLE, NO HARDWARE WILL EXTEND PAST THREE THREADS OUT OF THE NUT/THREADED HOLE.
- BACKPLANE AND DEAD FRONT IF REQUIRED ARE TO BE GROUNDED ACCORDING NEC 70E.
- UNLESS OTHERWISE NOTED, ALL CONTACTORS WILL BE AB 100-C, OVERLOADS AB 193 E-1, CONTROL RELAYS AB 700-HLT, AND CIRCUIT BREAKERS AB 1489.

**amiad**® WATER SYSTEMS 120-J TALBERT ROAD  
MOORESVILLE, NC 28117 USA  
(704) 662-3133 FAX (704) 662-3155

THIS DRAWING AND THE INFORMATION CONTAINED HEREIN IS THE PROPERTY OF AMIAD WATER SYSTEMS. ANY USE OR REPRODUCTION THEREOF WITHOUT THE WRITTEN PERMISSION OF AMIAD WATER SYSTEMS ENGINEERING DEPARTMENT IS STRICTLY PROHIBITED.

DRAWING DATE: 05/09/2014	DRAWING TITLE: 1F 460V/3~ UNI/SOL PEP 1-3.19A WIRING DIAGRAM	
SCALE: 1" = 3"	DRAWING NUMBER: 720102-002073-ELC	REV. NO. 5
SHT. 2 of 2	CATALOG NUMBER: 720102-002073	
DRAWN BY: JTE	GENERAL TOLERANCES (EXCEPT AS NOTED)	ANGULAR ±1° FRACTIONAL ± 1/8" DEC: 2PL±0.05", 3PL±0.010"

NO.	DATE	NOTES	BY	CHKD BY: ---	APP. BY: ---
GENERAL REVISIONS					