

460V/3φ/60 Hz

L1 L2 L3

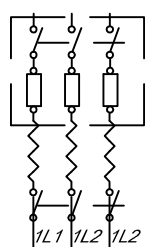

MAIN DISCONNECT AND BRANCH CIRCUIT PROTECTION PROVIDED BY OTHERS (MAXIMUM OF 90A DUAL TIME DELAY FUSE OR 90A INVERSE TIME BREAKER RECOMMENDED)

LOCKABLE NON-FUSED DISCONNECT SWITCH (RATED @ 80 AMPS)

| 150VA TRANSFORMER | |
|-------------------|--------|
| VOLTAGE | FUSING |
| 575 | 1A |
| 460 | 1A |
| 400 | 1A |
| 230 | 2A |
| 208 | 2A |

ALL FUSING TO BE LITTELFUSE CL. CC CCMR OR EQUIV.

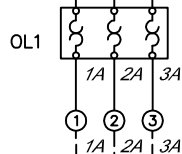
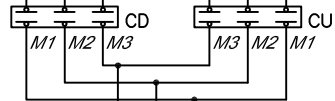
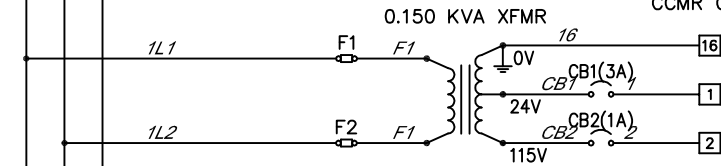

MAX. VOLTAGE: 600V
MAX. AMPERES: 5A

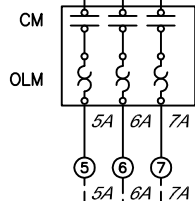

MAX. VOLTAGE: 600V
MAX. AMPERES: 40A

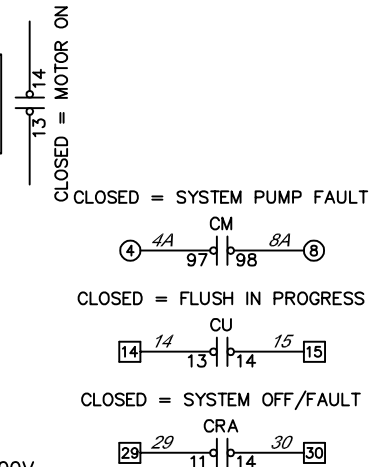

ALLEN BRADLEY
2080-LC10-12AWA

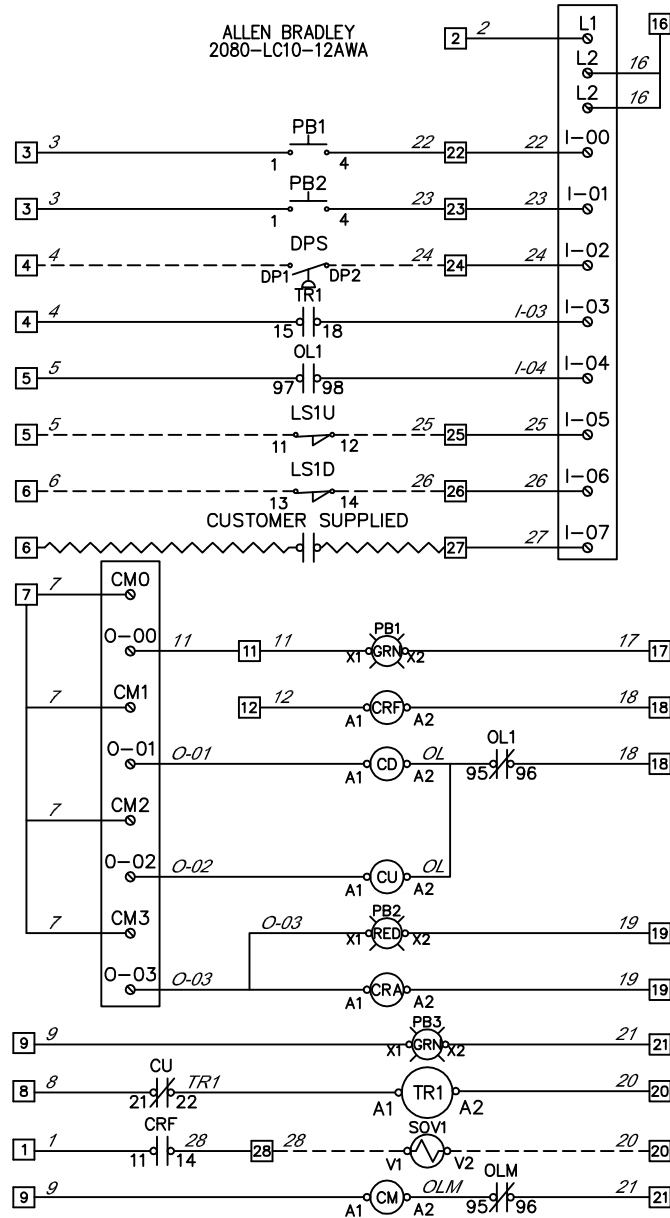

PLC POWER ON

FLUSH PUSHBUTTON

FAULT RESET PUSHBUTTON

DIFFERENTIAL PRESSURE

FLUSH INTERVAL TIMER

FAULT

UP LIMIT SWITCH

DOWN LIMIT SWITCH

REMOTE STOP

FLUSH PUSHBUTTON

FLUSH VALVE CONTROL

MOTOR DOWN

MOTOR UP

FAULT RESET PUSHBUTTON

FAULT CONTROL

POWER ON

FLUSH INTERVAL TIMER (0.05S-60HRS)

FLUSH VALVE

SYSTEM PUMP

| | |
|--------------|---------------------------------|
| POWER | 460V/3~/60HZ |
| TOTAL FLA | 45.33 AMPS |
| SCCR | 5 kA RMS SYMMETRICAL, 600V MAX. |
| LARGEST MTR. | 30 HP |

| | |
|-----------|-------------------|
| STANDARD | UL 508A |
| SIZE | 16"L x 14"W x 7"D |
| UL RATING | TYPE 4X |
| MATERIAL | POLYCARBONATE |

- GROUND PER 2011 NATIONAL ELECTRICAL CODE ARTICLE 250.
- PANEL WIRING: _____
FIELD WIRING: _____
CUSTOMER'S WIRING: _____
FACTORY INSTALLED JUMPER: _____
- USE COPPER WIRE RATED 60°C MINIMUM UNLESS OTHERWISE SPECIFIED.
- DISCONNECT SWITCH TORQUE REQUIREMENTS: 35 LB IN. CONTACTOR/OVERLOAD TORQUE REQUIREMENTS: 7-10 LB IN.
- SIZE THE MAIN DISCONNECT AND BRANCH CIRCUIT PROTECTION PER 2011 NATIONAL ELECTRIC CODE ARTICLE 430.

- CONDUIT HUBS AND FITTINGS MUST HAVE THE SAME UL ENVIRONMENTAL RATING AS THE CONTROL PANEL ENCLOSURE.
- WIRE COLORS ARE AS FOLLOWS-LINE=BLACK, AC=RED, NEUTRAL=WHITE, DC+=BLUE, DC-=WHITE/BLUE, GROUND=GREEN/YELLOW, EXTERNAL SOURCE=YELLOW.
- SET MOTOR OVERLOADS ACCORDING FLA ON MOTOR DATA PLATE
- ALL MOTOR WIRING TO BE AT LEAST CU. 75° RATED.
- TB1= [5] TBA= [1] TBB= [1]

Amiad WATER SYSTEMS
120-J TALBERT ROAD
MOORESVILLE, NC 28117 USA
(704) 662-3133 FAX (704) 662-3155

THIS DRAWING AND THE INFORMATION CONTAINED HEREIN IS THE PROPERTY OF AMIAD WATER SYSTEMS. ANY USE OR REPRODUCTION THEREOF WITHOUT THE WRITTEN PERMISSION OF AMIAD WATER SYSTEMS ENGINEERING DEPARTMENT IS STRICTLY PROHIBITED.

| | |
|-----------------------------|--|
| DRAWING DATE: 11/23/2015 | DRAWING TITLE: 1F 460V/3~ SOL AMD 1-5A, 16-40A WIRING DIAGRAM |
| SCALE: 1" = 1" | DRAWING NUMBER: 720102-000661-ELC |
| SHT. 1 of 2 | REV. NO. 0 |
| DRAWN BY: RAM | CATALOG NUMBER: 720102-000661 |
| CHKD BY: --- | GENERAL TOLERANCES (EXCEPT AS NOTED) |
| APP. BY: --- | ANGULAR ±1° FRACTIONAL ± 1/8" DEC: 2PL±0.05", 3PL±0.010" |

| NO. | DATE | NOTES | BY |
|-------------------|------|-------|----|
| GENERAL REVISIONS | | | |

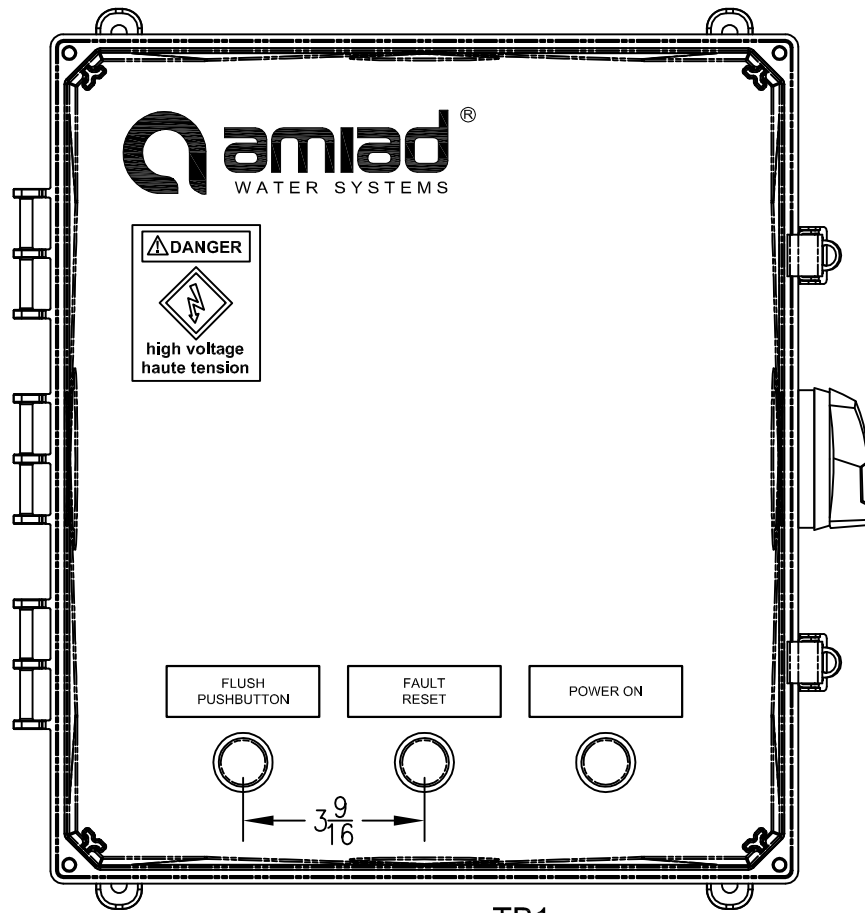

TB1

UPPER LEVEL

LOWER LEVEL

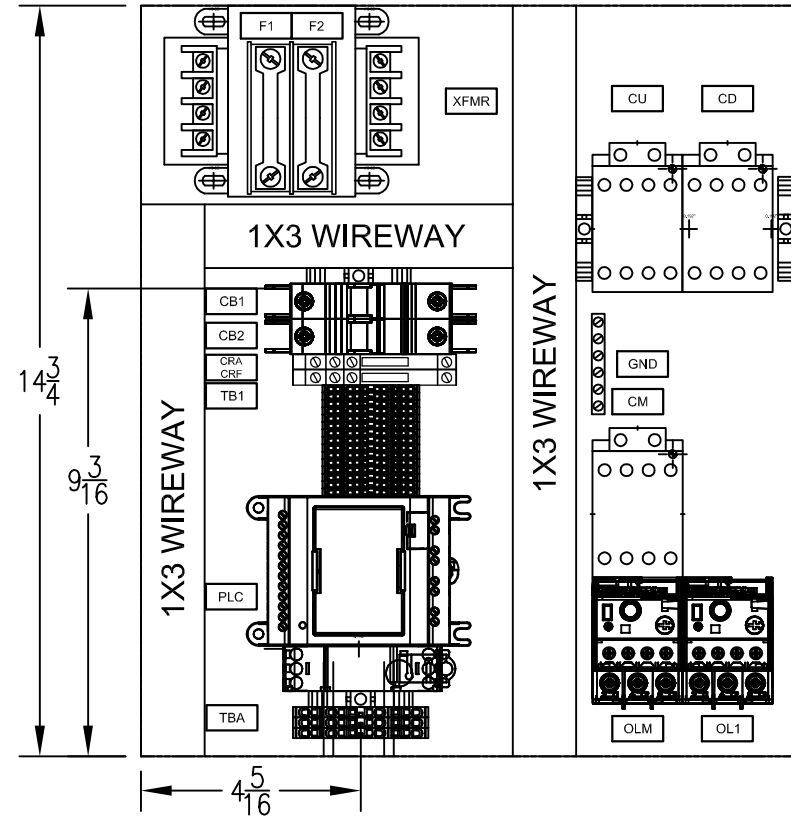
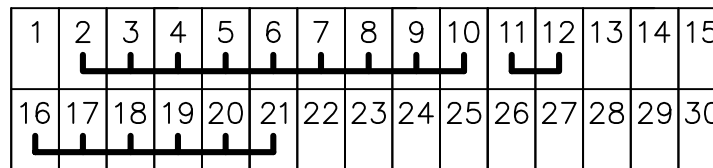

TBA

UPPER LEVEL

LOWER LEVEL

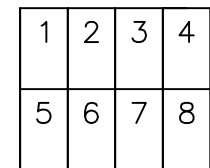

NOTE

1. ALL HARDWARE WILL INCLUDE ONE MECHANICAL LOCK AND A FLAT WASHER.
2. THE ONLY EXCEPTION IS IF THE MECHANICAL SCREW IS A SELF-THREADING SCREW.
3. IF BOLT/SCREW NEEDS TO GO THROUGH A THROUGH-HOLE, THE BOLT/SCREW WILL NEED A FLAT WASHER ON BOTH SIDES OF THE MATERIAL AND MECHANICAL LOCK BEFORE THE NUT.
4. ALL HARDWARE HAS TO THREAD AT LEAST TWO COMPLETE TURNS THROUGH THE NUT/THREADED HOLE
5. IF VISIBLE, NO HARDWARE WILL EXTEND PAST THREE THREADS OUT OF THE NUT/THREADED HOLE.
6. BACKPLANE AND DEAD FRONT IF REQUIRED ARE TO BE GROUNDED ACCORDING NEC 70E.
7. UNLESS OTHERWISE NOTED, ALL CONTACTORS WILL BE AB 100-C, OVERLOADS AB 193 E-1, CONTROL RELAYS AB 700-HLT, AND CIRCUIT BREAKERS AB 1489.

Amiad® WATER SYSTEMS 120-J TALBERT ROAD
MOORESVILLE, NC 28117 USA
(704) 662-3133 FAX (704) 662-3155

THIS DRAWING AND THE INFORMATION CONTAINED HEREIN IS THE PROPERTY OF AMIAD WATER SYSTEMS. ANY USE OR REPRODUCTION THEREOF WITHOUT THE WRITTEN PERMISSION OF AMIAD WATER SYSTEMS ENGINEERING DEPARTMENT IS STRICTLY PROHIBITED.

| | | |
|-----------------------------|---|--|
| DRAWING DATE: 11/23/2015 | DRAWING TITLE: 1F 460V/3~ SOL AMD 1-5A, 16-40A WIRING DIAGRAM | |
| SCALE: 1" = 4" | DRAWING NUMBER: 720102-000661-ELC | REV. NO. 0 |
| SHT. 2 of 2 | CATALOG NUMBER: 720102-000661 | |
| DRAWN BY: RAM | GENERAL TOLERANCES (EXCEPT AS NOTED) | ANGULAR ±1° FRACTIONAL ± 1/8" DEC: 2PL±0.05", 3PL±0.010" |
| NO. DATE | NOTES | BY |
| GENERAL REVISIONS | | |
| APP. BY: --- | CHKD BY: --- | |