

NOTES

- 1) ALL DIMENSIONS GIVEN IN INCHES UNLESS OTHERWISE SPECIFIED.
- 2) MAX OPERATING PRESSURE: 150 PSI
- 3) TANK CONSTRUCTION: CARBON STEEL
- 4) EXTERIOR: EPOXY/POWDER COATED
- 5) APPROXIMATE MASS: 956 LBS

#	COMPONENT
1	NEMA 4X, UL, 460V/3PH/60Hz CONTROL PANEL
2	SEPARATOR: 4" ICS, COATED CARBON STEEL
3	PUMP: 5HP 3600RPM, 460/3/60, 400 GPM @ 35' TDH
4	INLET/OUTLET PRESSURE GAUGES: 2.5" 0-160 PSI, LIQ FILLED
5	PRE-STRAINER: 5" TITAN BS-65 CI
6	PURGE VALVE: 1" FNPT FAIL SAFE COAXIAL VALVE
7	BASE: COATED CARBON STEEL I-BEAM
8	FACE PIPE: 4" PVC SCH 80

amiad[®] WATER SYSTEMS
 120-J TALBERT ROAD
 MOORESVILLE, NC 28117
 PH: (704) 662-3133
 FAX: (704) 662-3155

THIS DRAWING, AND THE INFORMATION CONTAINED HEREIN, IS THE PROPERTY OF AMIAD WATER SYSTEMS. ANY USE OR REPRODUCTION THEREOF WITHOUT THE WRITTEN PERMISSION OF AMIAD WATER SYSTEMS ENGINEERING DEPARTMENT IS STRICTLY PROHIBITED.

DRAWING DATE: 10/18/2018	DRAWING TITLE: ICS 400 GPM LH WITH FACE PIPING AND PUMP
SCALE: 1:20	DRAWING NUMBER: 200108-000043 LH-S 400GPM
SHEET 1 OF 2	CAT NUMBER: 200108-000043
DRAWN BY: MAV	REV. NO. 0
CHECKED BY: SAL	GENERAL TOLERANCES (EXCEPT AS NOTED)
APPROVED BY: _____	ANGULAR ± 1° FRACTIONAL ± 1/8" Dec: 2 PL ± 0.05", 3 PL ± 0.010"

NO.	REVISION NOTES	DATE	BY

460V/3 ϕ /60 Hz

L1 L2 L3

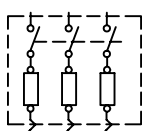

MAIN DISCONNECT AND BRANCH CIRCUIT PROTECTION PROVIDED BY OTHERS (MAXIMUM OF 29A DUAL TIME DELAY FUSE OR 42A INVERSE TIME BREAKER RECOMMENDED)

150VA TRANSFORMER		
Voltage	Fuse	Location
460	1A	H1-H4
230	2A	H2-H4
208	2A	H3-H4

LOCKABLE NON-FUSED DISCONNECT SWITCH (RATED @ 40 AMPS)

ALL PRIMARY FUSING TO BE LITTELFUSE CLASS CC, CCMR OR EQUIV.

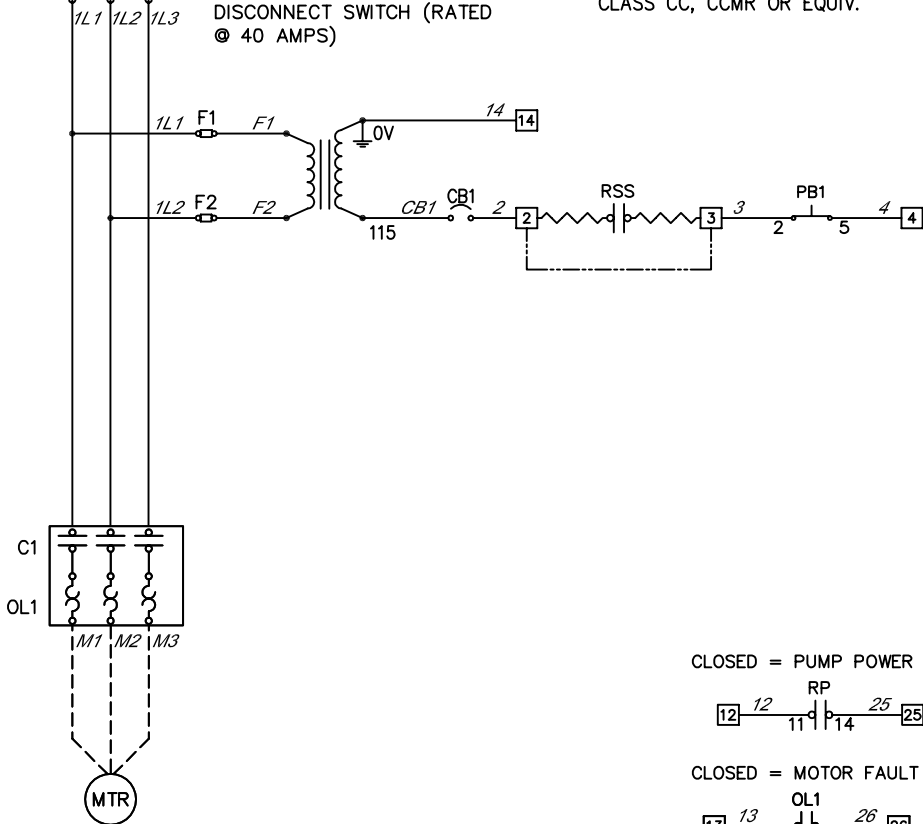

CLOSED = PUMP POWER ON



CLOSED = MOTOR FAULT

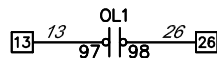

MAX. VOLTAGE: 600V
MAX. AMPERES: 16A

POWER	POWER	460V/3~/60HZ
	TOTAL FLA	16.33 AMPS
	SCCR	5 KA RMS SYMMETRICAL, 600V MAX.
	LARGEST MTR.	15 HP

ENCLOSURE	STANDARD	UL 508A
	SIZE	12"L x 10"W x 6"D
	UL RATING	TYPE 4X
	MATERIAL	POLYCARBONATE

- GROUND PER 2011 NATIONAL ELECTRICAL CODE ARTICLE 250.
- PANEL WIRING:
SHOP/FIELD WIRING: _____
CUSTOMER'S WIRING: _____
FACTORY INSTALLED JUMPER: _____
- USE COPPER WIRE RATED 60°C MINIMUM UNLESS OTHERWISE SPECIFIED.
- DISCONNECT SWITCH TORQUE REQUIREMENTS: 35 LB IN. CONTACTOR/OVERLOAD TORQUE REQUIREMENTS: 7-10 LB IN.
- SIZE THE MAIN DISCONNECT AND BRANCH CIRCUIT PROTECTION PER 2011 NATIONAL ELECTRIC CODE ARTICLE 430.

- CONDUIT HUBS AND FITTINGS MUST HAVE THE SAME UL ENVIRONMENTAL RATING AS THE CONTROL PANEL ENCLOSURE.
- WIRE COLORS ARE AS FOLLOWS-LINE=BLACK, AC=RED, NEUTRAL=WHITE, DC+=BLUE, DC-=WHITE/BLUE, GROUND=GREEN/YELLOW, EXTERNAL SOURCE=YELLOW.
- SET MOTOR OVERLOADS ACCORDING FLA ON MOTOR DATA PLATE
- ALL MOTOR WIRING TO BE AT LEAST CU, 75° RATED.
- TB1= [5] TBA= (1) TBB= (1)

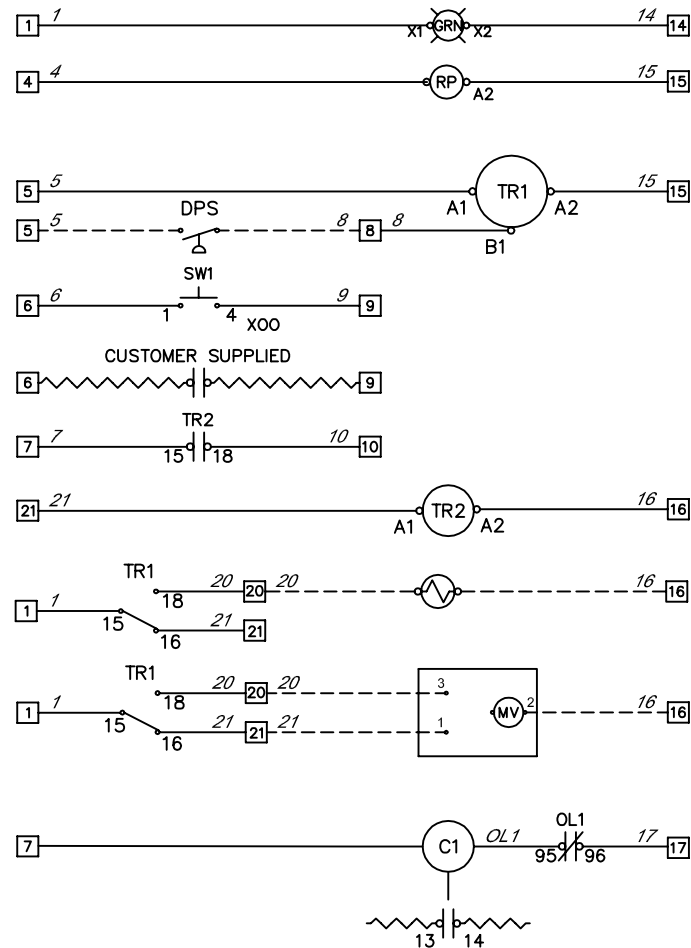

- POWER ON LIGHT
- PUMP POWER ON
- FLUSH DURATION (2 MIN)
- DIFFERENTIAL PRESSURE
- LOCAL FLUSH START
- REMOTE FLUSH START
- CYCLE TIMER
- CYCLE TIMER (0.05S-60HRS)
- FLUSH VALVE SOLENOID OPTION
- FLUSH VALVE (BATTERY BACKUP)
- SYSTEM PUMP

Amiad® WATER SYSTEMS 120-J TALBERT ROAD
MOORESVILLE, NC 28117 USA
(704) 662-3133 FAX (704) 662-3155

THIS DRAWING AND THE INFORMATION CONTAINED HEREIN IS THE PROPERTY OF AMIAD WATER SYSTEMS. ANY USE OR REPRODUCTION THEREOF WITHOUT THE WRITTEN PERMISSION OF AMIAD WATER SYSTEMS ENGINEERING DEPARTMENT IS STRICTLY PROHIBITED.

DRAWING DATE: 07/26/2018	DRAWING TITLE: 1F 460V/3~ VALBIA PEP 3.2-16A WIRING DIAGRAM
SCALE: 1" = 1"	DRAWING NUMBER: 720102-002486-ELC
SHT. 1 of 2	REV. NO. 0
DRAWN BY: RAM	CATALOG NUMBER: 720102-002486
CHKD BY: _____	GENERAL TOLERANCES (EXCEPT AS NOTED)
APP. BY: _____	ANGULAR ±1° FRACTIONAL ± 1/8" DEC: 2PL±0.05", 3PL±0.010"

NO.	DATE	NOTES	BY
GENERAL REVISIONS			

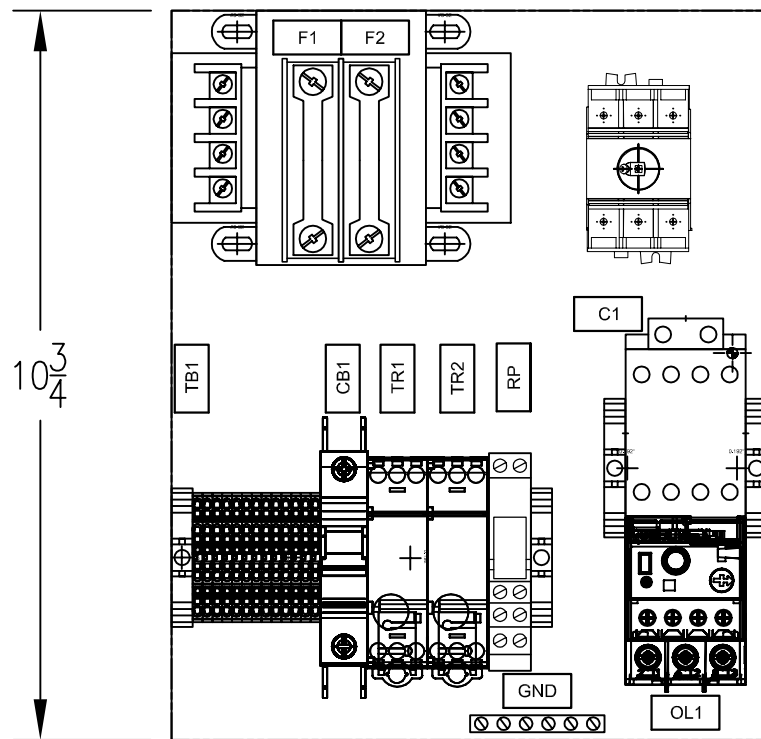
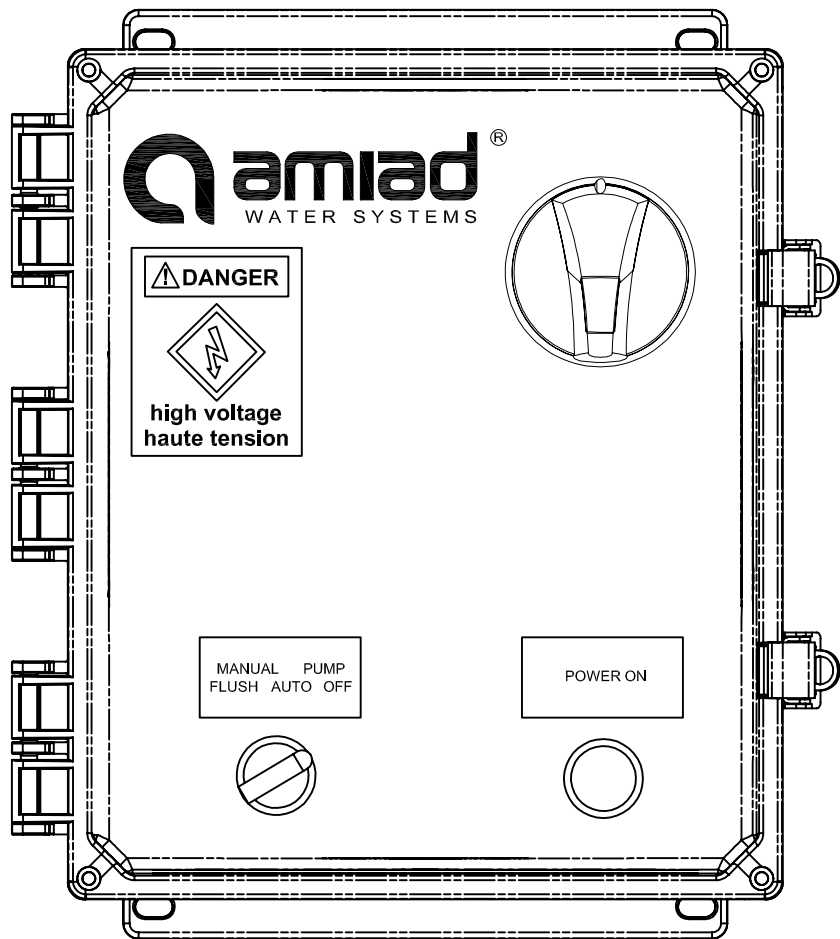

UPPER LEVEL

LOWER LEVEL

1	2	3	4	5	6	7	8	9	10	11	12	13
14	15	16	17	18	19	20	21	22	23	24	25	26

NOTE

- ALL HARDWARE WILL INCLUDE ONE MECHANICAL LOCK AND A FLAT WASHER.
- THE ONLY EXCEPTION IS IF THE MECHANICAL SCREW IS A SELF-THREADING SCREW.
- IF BOLT/SCREW NEEDS TO GO THROUGH A THROUGH-HOLE, THE BOLT/SCREW WILL NEED A FLAT WASHER ON BOTH SIDES OF THE MATERIAL AND MECHANICAL LOCK BEFORE THE NUT.
- ALL HARDWARE HAS TO THREAD AT LEAST TWO COMPLETE TURNS THROUGH THE NUT/THREADED HOLE
- IF VISIBLE, NO HARDWARE WILL EXTEND PAST THREE THREADS OUT OF THE NUT/THREADED HOLE.
- BACKPLANE AND DEAD FRONT IF REQUIRED ARE TO BE GROUNDED ACCORDING NEC 70E.
- UNLESS OTHERWISE NOTED, ALL CONTACTORS WILL BE AB 100-C, OVERLOADS AB 193 E-1, CONTROL RELAYS AB 700-HLT, AND CIRCUIT BREAKERS AB 1489.

Amiad® WATER SYSTEMS 120-J TALBERT ROAD MOORESVILLE, NC 28117 USA (704) 662-3133 FAX (704) 662-3155

THIS DRAWING AND THE INFORMATION CONTAINED HEREIN IS THE PROPERTY OF AMIAD WATER SYSTEMS. ANY USE OR REPRODUCTION THEREOF WITHOUT THE WRITTEN PERMISSION OF AMIAD WATER SYSTEMS ENGINEERING DEPARTMENT IS STRICTLY PROHIBITED.

DRAWING DATE: 07/26/2018	DRAWING TITLE: 1F 460V/3~ VALBIA PEP 3.2-16A WIRING DIAGRAM	
SCALE: 1" = 3"	DRAWING NUMBER: 720102-002486-ELC	REV. NO. 0
SHT. 2 of 2	CATALOG NUMBER: 720102-002486	
DRAWN BY: RAM	GENERAL TOLERANCES (EXCEPT AS NOTED)	ANGULAR ±1° FRACTIONAL ± 1/8" DEC: 2PL±0.05", 3PL±0.010"
NO. DATE	NOTES	BY
GENERAL REVISIONS		
CHKD BY: ---	APP. BY: ---	