

BASE DETAIL

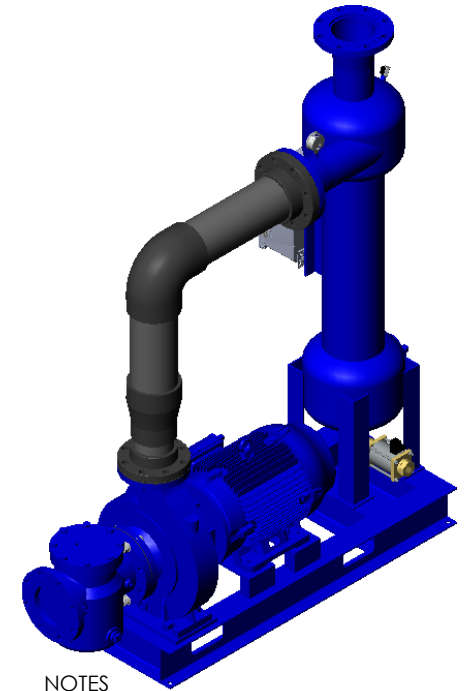

NOTES

- 1) ALL DIMENSIONS GIVEN IN INCHES UNLESS OTHERWISE SPECIFIED.
- 2) MAX OPERATING PRESSURE: 150 PSI
- 3) TANK CONSTRUCTION: CARBON STEEL
- 4) EXTERIOR: EPOXY COATED
- 5) APPROXIMATE MASS:
SHIPPING: 1610 LBS
OPERATING: 1898 LBS

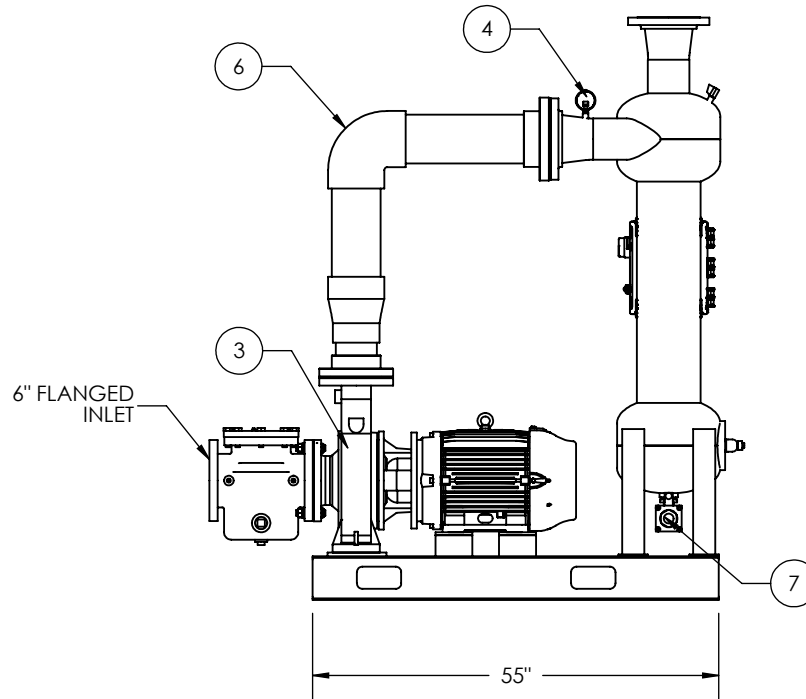
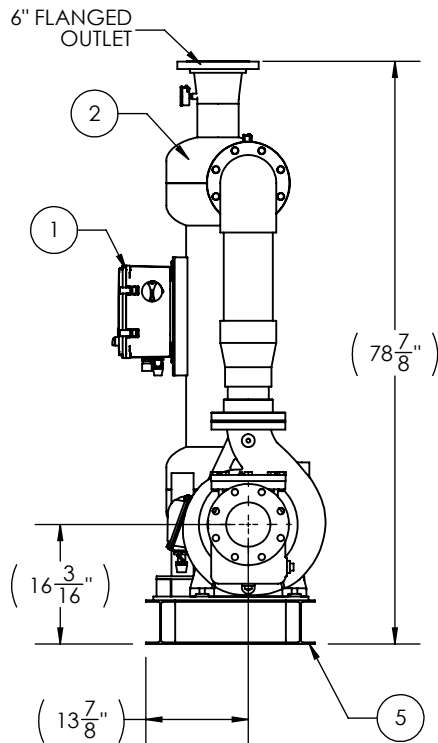

#	COMPONENT
1	NEMA 4X, UL, 460V/3PH/60Hz CONTROL PANEL
2	SEPARATOR: 5" ICS, EPOXY COATED CARBON STEEL
3	PUMP: 25HP 1750RPM, 460/3/60, 850 GPM @ 70' TDH
4	INLET/OUTLET PRESSURE GAUGES: 2.5" 0-160 PSI, LIQ FILLED
5	BASE: EPOXY COATED STEEL I-BEAM
6	FACE PIPE: 6" PVC SCH 80
7	PURGE: 120V COAXIAL SOLENOID VALVE

amiad WATER SYSTEMS
 120-J TALBERT ROAD
 MOORESVILLE, NC 28117
 PH: (704) 662-3133
 FAX: (704) 662-3155

THIS DRAWING, AND THE INFORMATION CONTAINED HEREIN, IS THE PROPERTY OF AMIAD WATER SYSTEMS. ANY USE OR REPRODUCTION THEREOF WITHOUT THE WRITTEN PERMISSION OF AMIAD WATER SYSTEMS ENGINEERING DEPARTMENT IS STRICTLY PROHIBITED.

DRAWING DATE: 11/10/2017	DRAWING TITLE: ICS 850 GPM HH WITH FACE PIPING AND PUMP
SCALE: 1:26	DRAWING NUMBER: 200109-000039 ASY-850GPM HH-S
SHEET 1 OF 2	CAT NUMBER: 200109-000039
DRAWN BY: MAV	REV. NO. 0
CHECKED BY: SAL	GENERAL TOLERANCES (EXCEPT AS NOTED)
APPROVED BY: _____	ANGULAR ± 1° FRACTIONAL ± 1/8" Dec: 2 PL ± 0.05", 3 PL ± 0.010"

NO.	REVISION NOTES	DATE	BY

460V/3 ϕ /60 Hz

L1 L2 L3

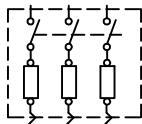

MAIN DISCONNECT AND BRANCH CIRCUIT PROTECTION PROVIDED BY OTHERS (MAXIMUM OF 70A DUAL TIME DELAY FUSE OR 100A INVERSE TIME BREAKER RECOMMENDED)

150VA TRANSFORMER		
Voltage	Fuse	Location
460	1A	H1-H4
230	2A	H2-H4
208	2A	H3-H4

LOCKABLE NON-FUSED DISCONNECT SWITCH (RATED @ 40 AMPS)

ALL PRIMARY FUSING TO BE LITTELFUSE CLASS CC, CCMR OR EQUIV.

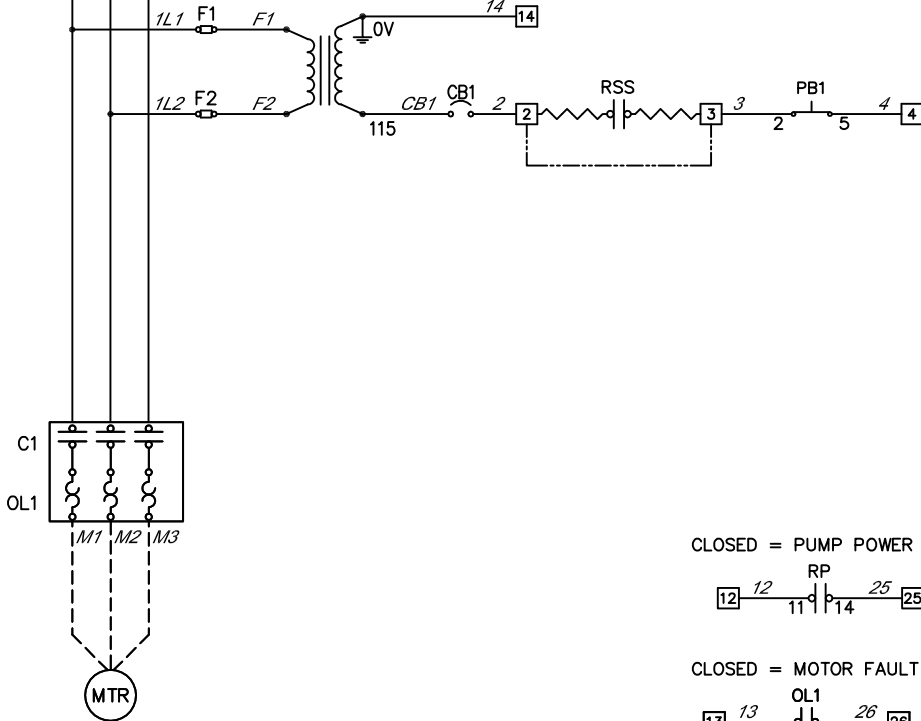

CLOSED = PUMP POWER ON

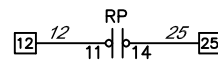

CLOSED = MOTOR FAULT

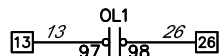

MAX. VOLTAGE: 600V
MAX. AMPERES: 39.00A

POWER	POWER	460V/3~ /60HZ
	TOTAL FLA	40 AMPS
	SCCR	5 kA RMS SYMMETRICAL, 600V MAX.
	LARGEST MTR.	35 HP

ENCLOSURE	STANDARD	UL 508A
	SIZE	12"L x 10"W x 6"D
	UL RATING	TYPE 4X
	MATERIAL	POLYCARBONATE

- GROUND PER 2011 NATIONAL ELECTRICAL CODE ARTICLE 250.
- PANEL WIRING:
SHOP/FIELD WIRING: _____
CUSTOMER'S WIRING: _____
FACTORY INSTALLED JUMPER: _____
- USE COPPER WIRE RATED 60°C MINIMUM UNLESS OTHERWISE SPECIFIED.
- DISCONNECT SWITCH TORQUE REQUIREMENTS: 35 LB IN. CONTACTOR/OVERLOAD TORQUE REQUIREMENTS: 7-10 LB IN.
- SIZE THE MAIN DISCONNECT AND BRANCH CIRCUIT PROTECTION PER 2011 NATIONAL ELECTRICAL CODE ARTICLE 430.

- CONDUIT HUBS AND FITTINGS MUST HAVE THE SAME UL ENVIRONMENTAL RATING AS THE CONTROL PANEL ENCLOSURE.
- WIRE COLORS ARE AS FOLLOWS—LINE=BLACK, AC=RED, NEUTRAL=WHITE, DC+=BLUE, DC-=WHITE/BLUE, GROUND=GREEN/YELLOW, EXTERNAL SOURCE=YELLOW.
- SET MOTOR OVERLOADS ACCORDING FLA ON MOTOR DATA PLATE
- ALL MOTOR WIRING TO BE AT LEAST CU, 75° RATED.
- TB1= [5] TBA= (1) TBB= (1)

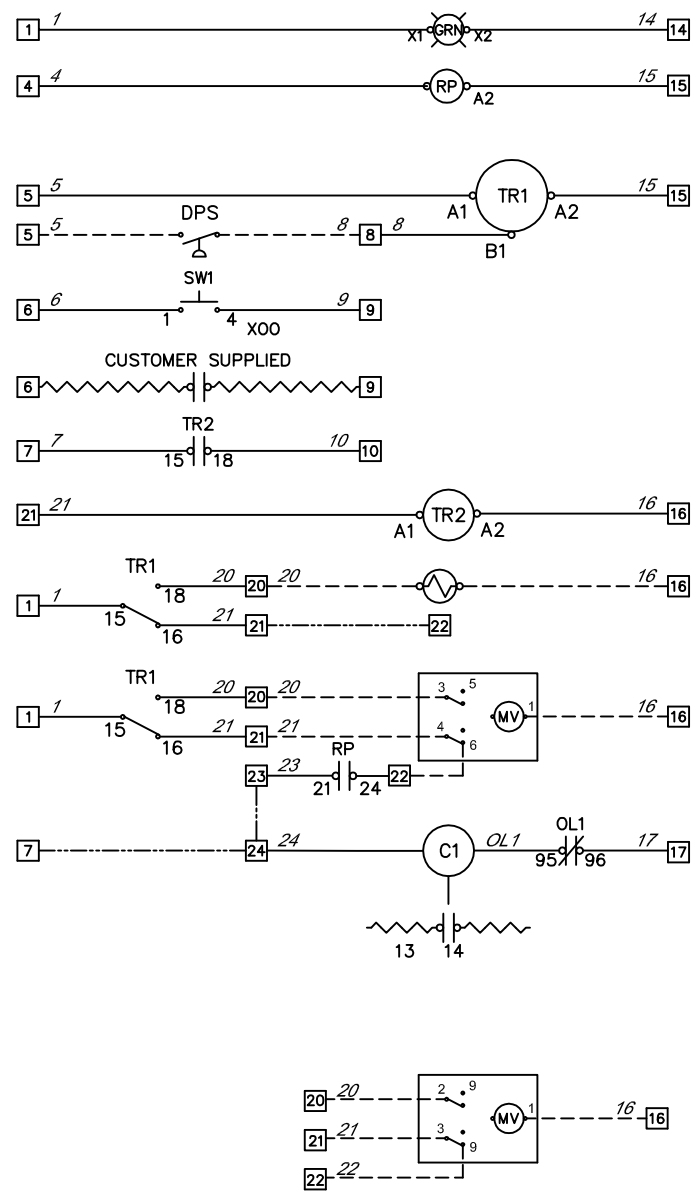

- POWER ON LIGHT
- PUMP POWER ON
- FLUSH DURATION (2 MIN) DIFFERENTIAL PRESSURE
- LOCAL FLUSH START
- REMOTE FLUSH START
- CYCLE TIMER
- CYCLE TIMER (0.05S-60HRS) FLUSH VALVE OPTIONS (SHOP TO ADD JUMPER FROM TB21 TO TB22 IF SOLENOID FLUSH VALVE IS USED)
- SYSTEM PUMP (REMOVE JUMPER FROM TB7 TO TB24 FOR EXTERNAL SOURCE FLUSH; REMOVE MECHANICAL JUMPER FROM TB23 TO TB24 FOR SYSTEM FLUSH)
- MOTOR ON DRY CONTACTS
- OPTIONAL BRAY ACTUATOR

Amiad WATER SYSTEMS 120-J TALBERT ROAD MOORESVILLE, NC 28117 USA (704) 662-3133 FAX (704) 662-3155

THIS DRAWING AND THE INFORMATION CONTAINED HEREIN IS THE PROPERTY OF AMIAD WATER SYSTEMS. ANY USE OR REPRODUCTION THEREOF WITHOUT THE WRITTEN PERMISSION OF AMIAD WATER SYSTEMS ENGINEERING DEPARTMENT IS STRICTLY PROHIBITED.							
5	10/5/2017	DELETE COUNTER	RAM	DRAWING DATE:	05/09/2014	DRAWING TITLE:	1F 460V/3~ UNI/SOL PEP 16.01-40A WIRING DIAGRAM
4	08/31/2016	ADD COUNTER, FIX PUMP "SOURCE" POWER	RAM	SCALE:	1" = 1"	DRAWING NUMBER:	720102-002093-ELC
3	07/27/2015	ADD OPTIONAL BRAY ACTUATOR	RAM	SHT.	1 of 2	REV. NO.	5
2	07/10/2014	MOTOR CONTROL	CEH	DRAWN BY:	JTE	CATALOG NUMBER:	720102-002093
1	06/03/2014	WIRE LABELS	JTE	CHKD BY:	---	GENERAL TOLERANCES	(EXCEPT AS NOTED)
NO.		DATE	NOTES	BY	CHKD BY:	ANGULAR	±1°
GENERAL REVISIONS				APP. BY:	---	FRACTIONAL	± 1/8"
						DEC:	2PL±0.05", 3PL±0.010"

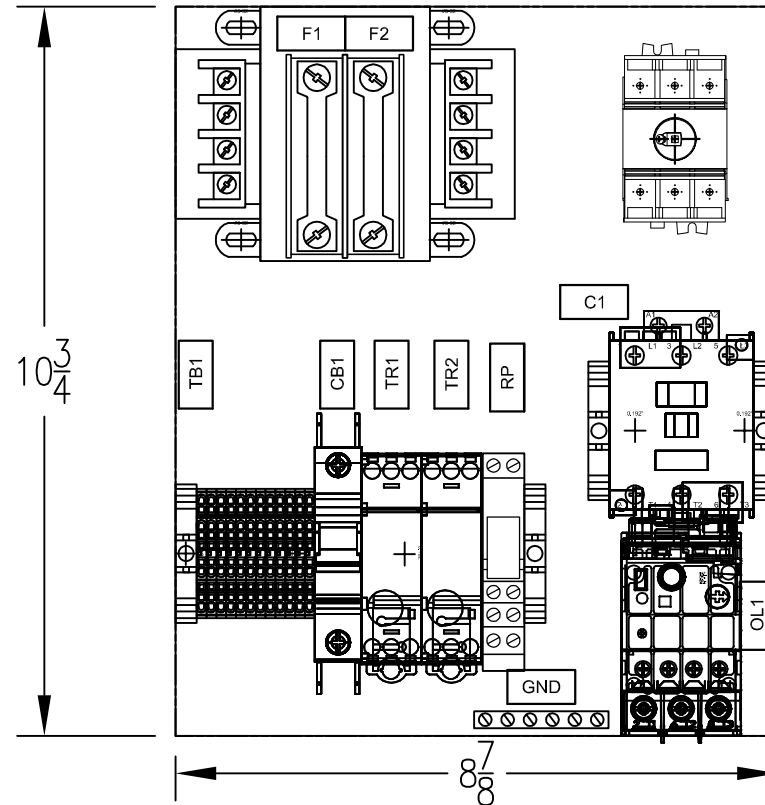
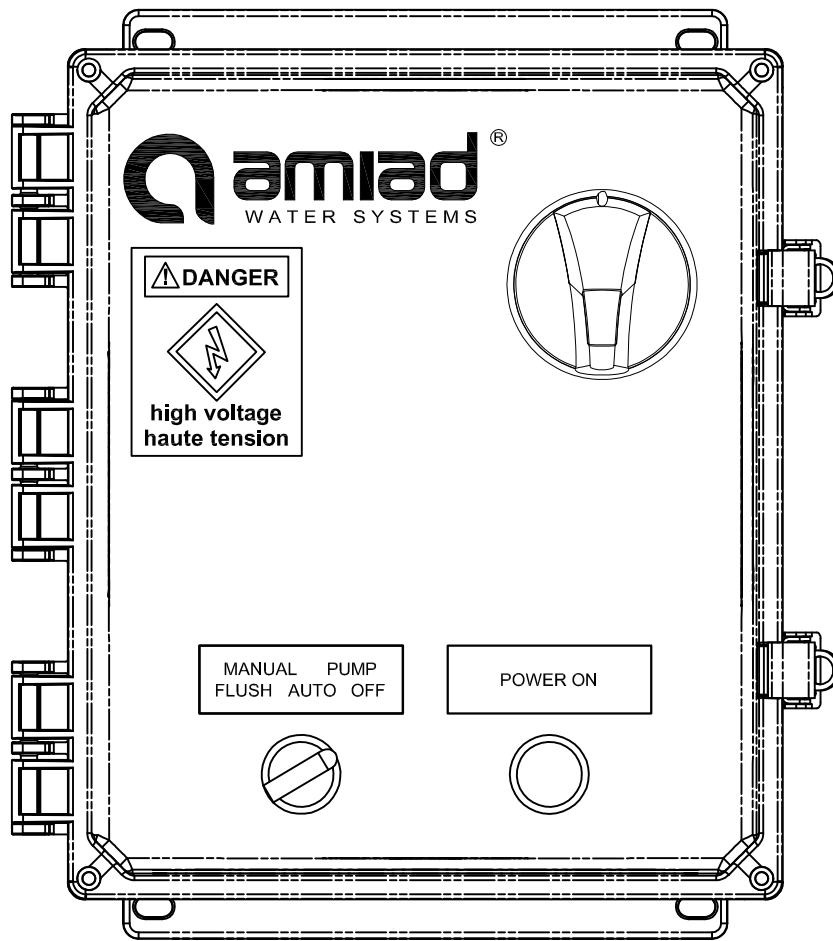

UPPER LEVEL

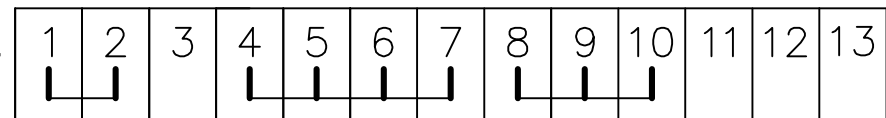

LOWER LEVEL

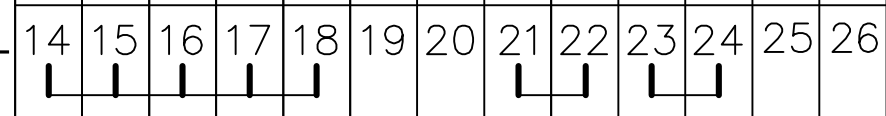

NOTE

1. ALL HARDWARE WILL INCLUDE ONE MECHANICAL LOCK AND A FLAT WASHER.
2. THE ONLY EXCEPTION IS IF THE MECHANICAL SCREW IS A SELF-THREADING SCREW.
3. IF BOLT/SCREW NEEDS TO GO THROUGH A THROUGH-HOLE, THE BOLT/SCREW WILL NEED A FLAT WASHER ON BOTH SIDES OF THE MATERIAL AND MECHANICAL LOCK BEFORE THE NUT.
4. ALL HARDWARE HAS TO THREAD AT LEAST TWO COMPLETE TURNS THROUGH THE NUT/THREADED HOLE
5. IF VISIBLE, NO HARDWARE WILL EXTEND PAST THREE THREADS OUT OF THE NUT/THREADED HOLE.
6. BACKPLANE AND DEAD FRONT IF REQUIRED ARE TO BE GROUNDED ACCORDING NEC 70E.
7. UNLESS OTHERWISE NOTED, ALL CONTACTORS WILL BE AB 100-C, OVERLOADS AB 193 E-1, CONTROL RELAYS AB 700-HLT, AND CIRCUIT BREAKERS AB 1489.

amiad® WATER SYSTEMS 120-J TALBERT ROAD
MOORESVILLE, NC 28117 USA
(704) 662-3133 FAX (704) 662-3155

THIS DRAWING AND THE INFORMATION CONTAINED HEREIN IS THE PROPERTY OF AMIAD WATER SYSTEMS. ANY USE OR REPRODUCTION THEREOF WITHOUT THE WRITTEN PERMISSION OF AMIAD WATER SYSTEMS ENGINEERING DEPARTMENT IS STRICTLY PROHIBITED.

DRAWING DATE: 05/09/2014	DRAWING TITLE: 1F 460V/3~ UNI/SOL PEP 16.01-40A WIRING DIAGRAM				
SCALE: 1" = 3"	DRAWING NUMBER: 720102-002093-ELC				
SHT. 2 of 2	REV. NO. 5				
DRAWN BY: JTE	CATALOG NUMBER: 720102-002093				
NO. DATE	NOTES	BY	CHKD BY: ---	GENERAL TOLERANCES (EXCEPT AS NOTED)	ANGULAR ±1° FRACTIONAL ± 1/8" DEC: 2PL±0.05", 3PL±0.010"
GENERAL REVISIONS					
APP. BY: ---					