

460V/3φ/60 Hz

L1 L2 L3

MAIN DISCONNECT AND BRANCH CIRCUIT PROTECTION PROVIDED BY OTHERS (MAXIMUM OF 70A DUAL TIME DELAY FUSE OR 100A INVERSE TIME BREAKER RECOMMENDED)

150VA TRANSFORMER		
Voltage	Fuse	Location
460	1A	H1-H4
230	2A	H2-H4
208	2A	H3-H4

LOCKABLE NON-FUSED DISCONNECT SWITCH (RATED @ 40 AMPS)

ALL PRIMARY FUSING TO BE LITTELFUSE CLASS CC, CCMR OR EQUIV.

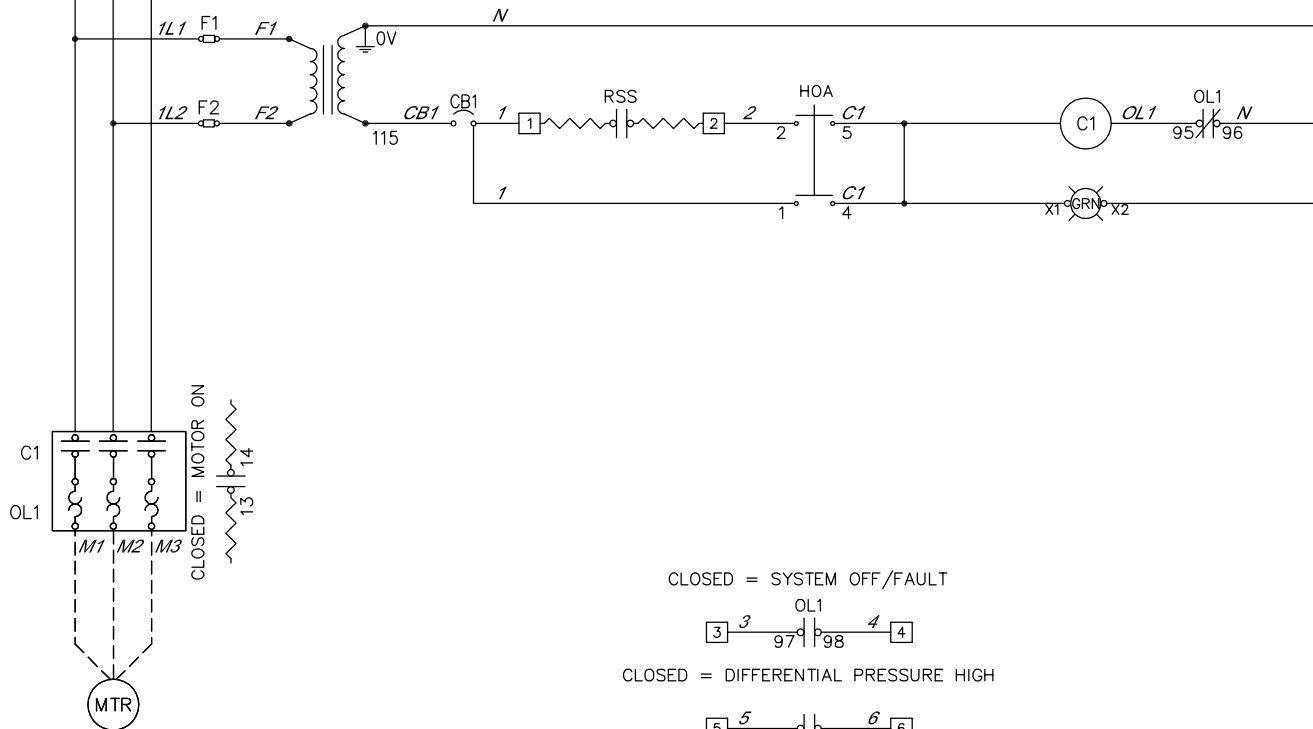

CLOSED = MOTOR ON

CLOSED = SYSTEM OFF/FAULT

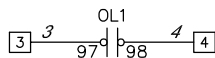

CLOSED = DIFFERENTIAL PRESSURE HIGH

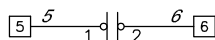

MAX. VOLTAGE: 600V
MAX. AMPERES: 39.67A

POWER	POWER	460V/3~/60HZ	ENCLOSURE	STANDARD	UL 508A
	TOTAL FLA	40 AMPS		SIZE	12"L x 10"W x 6"D
	SCCR	5 kA RMS SYMMETRICAL, 600V MAX.		UL RATING	TYPE 4X
	LARGEST MTR.	30 HP		MATERIAL	POLYCARBONATE

- GROUND PER 2011 NATIONAL ELECTRICAL CODE ARTICLE 250.
- PANEL WIRING: _____
SHOP WIRING: _____
CUSTOMER'S WIRING: _____
FACTORY INSTALLED JUMPER: _____
- USE COPPER WIRE RATED 60°C MINIMUM UNLESS OTHERWISE SPECIFIED.
- DISCONNECT SWITCH TORQUE REQUIREMENTS: 35 LB IN. CONTACTOR/OVERLOAD TORQUE REQUIREMENTS: 7-10 LB IN.
- SIZE THE MAIN DISCONNECT AND BRANCH CIRCUIT PROTECTION PER 2011 NATIONAL ELECTRIC CODE ARTICLE 430.

- CONDUIT HUBS AND FITTINGS MUST HAVE THE SAME UL ENVIRONMENTAL RATING AS THE CONTROL PANEL ENCLOSURE.
- WIRE COLORS ARE AS FOLLOWS-LINE=BLACK, AC=RED, NEUTRAL=WHITE, DC+=BLUE, DC-=WHITE/BLUE, GROUND=GREEN/YELLOW, EXTERNAL SOURCE=YELLOW.
- SET MOTOR OVERLOADS ACCORDING FLA ON MOTOR DATA PLATE.
- ALL MOTOR WIRING TO BE AT LEAST CU. 75° RATED.

NO.	DATE	NOTES	BY
GENERAL REVISIONS			



120-J TALBERT ROAD
MOORESVILLE, NC 28117 USA
(704) 662-3133 FAX (704) 662-3155

THIS DRAWING AND THE INFORMATION CONTAINED HEREIN IS THE PROPERTY OF AMIAD WATER SYSTEMS. ANY USE OR REPRODUCTION THEREOF WITHOUT THE WRITTEN PERMISSION OF AMIAD WATER SYSTEMS ENGINEERING DEPARTMENT IS STRICTLY PROHIBITED.

DRAWING DATE: 06/10/2014		DRAWING TITLE: 1F 460V/3~ DP NO TIMER 9-40A WIRING DIAGRAM	
SCALE: 1" = 1"	SHT. 1 of 2	DRAWING NUMBER: 720102-000540-ELC	REV. NO. 0
DRAWN BY: JTE		CATALOG NUMBER: 720102-000540	
CHKD BY: ---	APP. BY: ---	GENERAL TOLERANCES (EXCEPT AS NOTED)	ANGULAR ±1° FRACTIONAL ± 1/8" DEC: 2PL±0.05", 3PL±0.010"

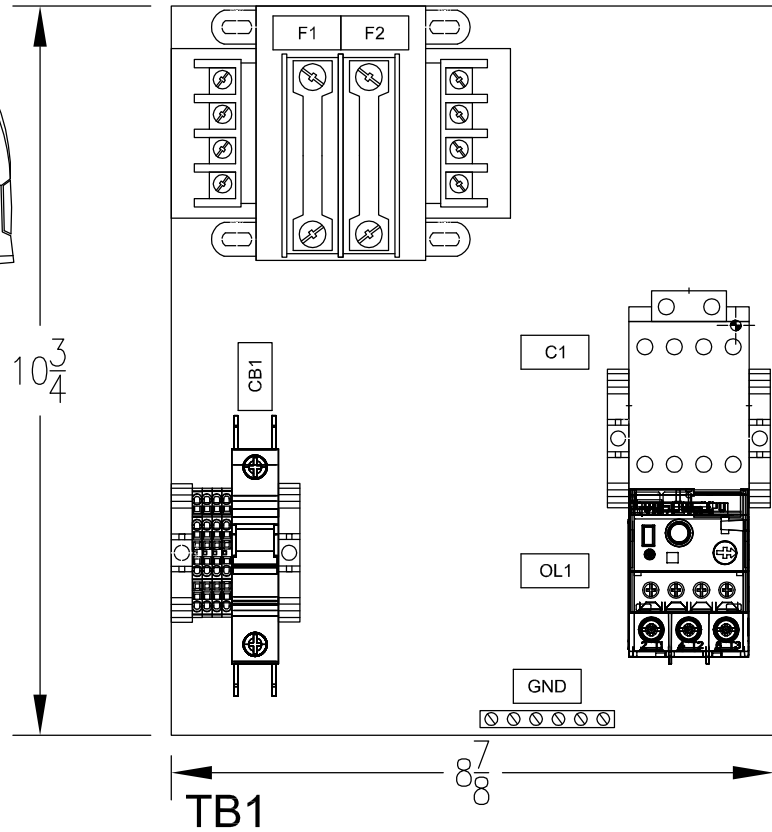
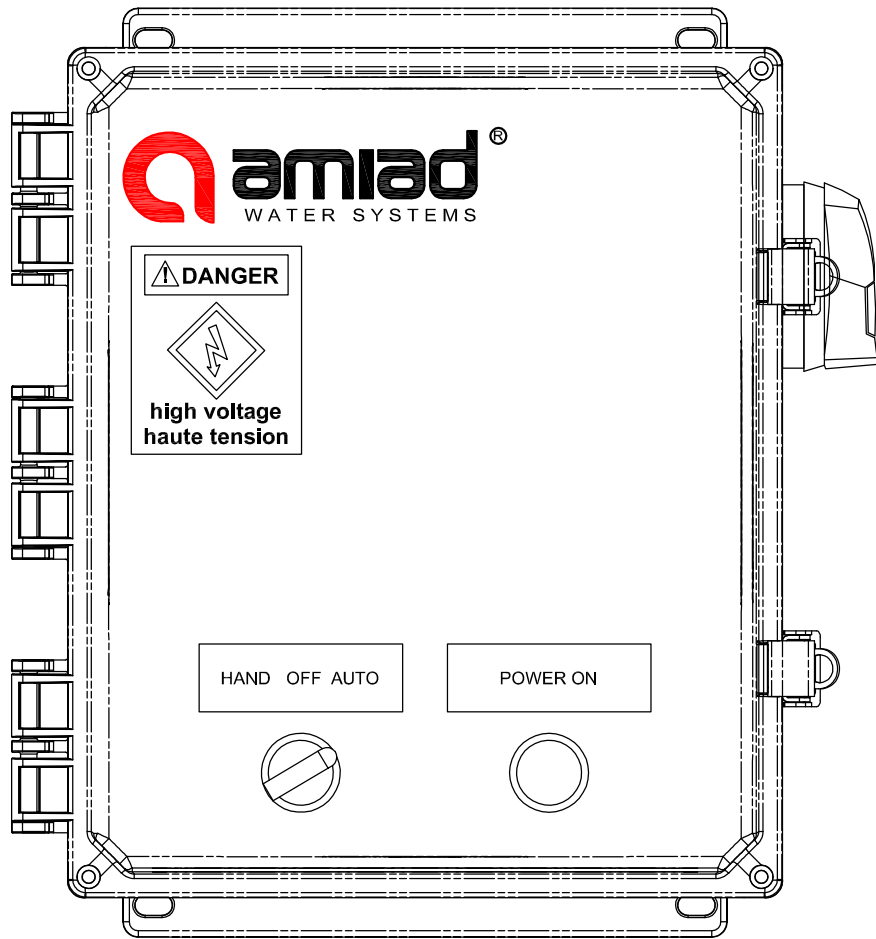

UPPER LEVEL

LOWER LEVEL

1	2	3	4
5	6	7	8

NOTE

1. ALL HARDWARE WILL INCLUDE ONE MECHANICAL LOCK AND A FLAT WASHER.
2. THE ONLY EXCEPTION IS IF THE MECHANICAL SCREW IS A SELF-THREADING SCREW.
3. IF BOLT/SCREW NEEDS TO GO THROUGH A THROUGH-HOLE, THE BOLT/SCREW WILL NEED A FLAT WASHER ON BOTH SIDES OF THE MATERIAL AND MECHANICAL LOCK BEFORE THE NUT.
4. ALL HARDWARE HAS TO THREAD AT LEAST TWO COMPLETE TURNS THROUGH THE NUT/THREADED HOLE
5. IF VISIBLE, NO HARDWARE WILL EXTEND PAST THREE THREADS OUT OF THE NUT/THREADED HOLE.
6. BACKPLANE AND DEAD FRONT IF REQUIRED ARE TO BE GROUNDED ACCORDING NEC 70E.
7. UNLESS OTHERWISE NOTED, ALL CONTACTORS WILL BE AB 100-C, OVERLOADS AB 193 E-1, CONTROL RELAYS AB 700-HLT, AND CIRCUIT BREAKERS AB 1489.

amiad® WATER SYSTEMS 120-J TALBERT ROAD
MOORESVILLE, NC 28117 USA
(704) 662-3133 FAX (704) 662-3155

THIS DRAWING AND THE INFORMATION CONTAINED HEREIN IS THE PROPERTY OF AMIAD WATER SYSTEMS. ANY USE OR REPRODUCTION THEREOF WITHOUT THE WRITTEN PERMISSION OF AMIAD WATER SYSTEMS ENGINEERING DEPARTMENT IS STRICTLY PROHIBITED.

DRAWING DATE: 06/10/2014	DRAWING TITLE: 1F 460V/3~ DP NO TIMER 9-40A WIRING DIAGRAM
SCALE: 1" = 3"	DRAWING NUMBER: 720102-000540-ELC
SHT. 2 of 2	REV. NO. 0
DRAWN BY: JTE	CATALOG NUMBER: 720102-000540
CHKD BY: ---	GENERAL TOLERANCES (EXCEPT AS NOTED)
APP. BY: ---	ANGULAR ±1° FRACTIONAL ± 1/8" DEC: 2PL±0.05", 3PL±0.010"

NO.	DATE	NOTES	BY
GENERAL REVISIONS			