

SMF Series Pre-Engineered HVAC Filter Skid

Installation, Operation and Maintenance Instructions

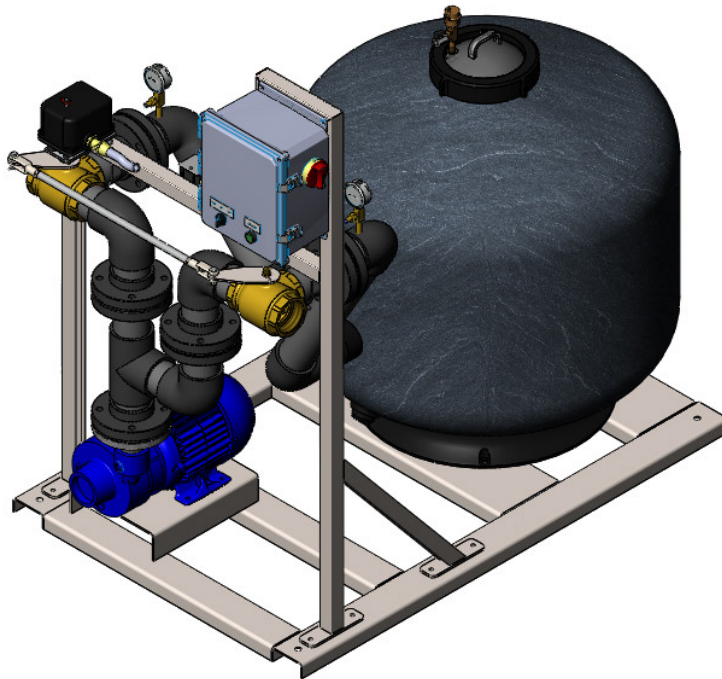

Disclaimer:

This document and the information enclosed within it contain restricted and/or privileged information that are intended only for usage by authorized Amiad technicians. If you are not a qualified Amiad technician you must not take any action in reliance on this document, unless permitted by Amiad.

None of the procedures provided in this file may be used in any form or by any means without permission from Amiad.

If you received this file in error, please notify Amiad immediately.

The confidential nature of and/or privilege in the file enclosed is not waived or lost as a result of a mistake or error in this file.

Amiad accepts no liability whatsoever, whether it was caused by:

1. Accessing or other related actions to this file.
2. Any links, procedures or materials provided/attached to this file.

Amiad assumes that all users understand risks involved within this file and/or its attached materials.

All the procedures, drawings, pictures and/or any other information provided in this document are presented as general information only; they can be altered, removed or changed without any further notice by Amiad.

This document does not replace any certified drawing, procedure or information provided by Amiad in reference to a specific customer, site or project.

All rights reserved.



AMIAD



FILTOMAT



ARKAL



PEP

Table of Contents

Introduction	Page 3
Installation.....	3
Start-up & Operation	5
Maintenance Procedures	7
Water Treatment	7
Factory Authorized Parts	8
Safety Precautions	8
Amiad Limited Warranty	9
Table 1 – SMF Service Schedule	10
Table 2 – SMF Connections.....	11
Table 3 – SMF Flow Rates	11
Table 4A & B – SMF Electrical Requirements, 50 & 60 Hz.....	11
Table 5 – SMF Media Quantity.....	12
Table 6A & B – SMF Replacement Parts	12
Table 7 – Troubleshooting	17
Pump Curves.....	19
Level I Controller	25
Appendix 1 – Pump IOM	34

Introduction

Amiad filtration equipment has been designed to give long term, trouble-free service when properly installed, operated and maintained. This manual contains important installation procedures and should be read prior to installing. This manual is also a guide for proper filter operation, maintenance and winterizing. It is important that maintenance personnel review this manual carefully, including the Safety Precautions and Warnings before performing any maintenance on this sand media water filter.

Note that the recommendations on the frequency service are minimums, and where operating conditions are severe, the service should be performed more often. For each required service, follow the procedures outlined under the Maintenance Procedures section in this manual. If additional information beyond the scope of this manual is required, contact your local Amiad Representative or the factory.

General Description

The SMF Series Sand Media Filters are permanent media type units specifically designed to clean process water. The filters may be used for both side-stream and full stream applications in pressurized and non-pressurized systems. Standard SMF series filter vessels are rated for 50 PSI for the 20" thru 48" tanks. All pressure ratings are based on a maximum temperature of 100 degrees Fahrenheit.

Filter Operation

Water from the system is pumped through the over-drain assembly at the top of the filter tank and distributed evenly over the media. Unfiltered water flows downward through the filter media where suspended particles are trapped. The filtered water then passes through the vessel and out the under-drain assembly at the bottom of the filter and returns to the system.

When the trapped particles cause the pressure differential across the media bed to reach a pre-determined pressure of approximately 16 PSI flow is reversed through the tank by repositioning the valves automatically or manually. The media is backwashed with a rigorous scouring action, releasing trapped particles within the media. The dirty water passes from the filter vessel through the over-drain assembly at the top of the vessel and flows to drain. After the backwash cycle (field adjustable and factory pre-set at 2 minutes), the filter valves are again repositioned and the filtration cycle is resumed.

Installation

CAUTION!!! Water sources vary and may contain impurities that can adversely affect a filter system. Minerals, biological microbes and other impurities must be identified and addressed by each user on a case-by-case basis. Contact your filtration system dealer or the factory for additional information and recommendations.

Please review installation and operations manuals of individual parts within the system. This manual may not cover all processes and/or procedures of these parts.

Unpacking

When the Amiad SMF Media Filter is delivered to the jobsite, it should be inspected thoroughly to ensure that all required items have been received and that filter equipment is free of any damage that may have occurred in transit. Any damage must be noted on the bill of lading at the time of receipt. Without this, there is no recourse to recover the cost of damaged goods. The filter model number appears on a nameplate located on the unit and should be checked against the invoice/packing list.

Rigging

Amiad SMF filters should be lifted with a forklift or overhead crane. If these units are lifted with an overhead crane, lifting straps must be located below the filter skid and should not come in contact with the filter components. If no skid is supplied, lift from the lifting lugs located on the filter vessel top.

All Amiad SMF filters should be rigidly anchored to the floor or support steel by means of anchor bolts. All SMF filters have an anchoring provision. Once the filter is installed in its permanent location, the pressure gauge and air relief valves should be installed on the top of the filter tank (some units will have these items already installed). The sand media is loaded into the filter next. Refer to the section

in this manual "Loading the Media" for the proper loading procedure and the appropriate quantity of media necessary for each size filter vessel.

Piping

The Amiad SMF should be installed using the pipe size indicated in *Table 2*.

Connect the unfiltered source water from the system sump or piping to the connection labeled "Inlet".

NOTE: All Amiad SMF systems have end suction centrifugal style pumps that require flooded suction for proper operation. Piping to the pump suction inlet should be plumbed to ensure the pipe is full of water at all times.

Connect the return line from the connection labeled "Outlet" to the system sump or filtered water return piping.

A service or isolation valve should be installed on the inlet, outlet and city water line (if city water is used) to allow filter servicing. For units using a backwash source other than the system sump, refer to *Table 3* for the required backwash flow rate. The maximum city water backwash supply pressure to the filter vessel should never exceed the vessel pressure rating (50 PSI as standard). If public or municipal water is used for backwash, a back/low prevention device or check valve is required on the city water line (in accordance with local or other governing codes).

A backwash throttle valve should be placed on the backwash discharge manifold to control the volume of water that can escape during backwash. Obtaining the proper flow rate of the backwash water is essential for effective flushing of the media. Too high of a flow will flush all of the media out of the tank. Too low of a flow will not allow the media to gently lift, fluidize and flush filtered particulates from the media in the system. The proper flow rate is dependent on the size of the tank being flushed. The most common way to adjust the backwash throttle valve is to manually set the filter(s) to backwash with the throttle valve fully closed. Slowly open the throttle valve until small amounts of media are evident in the backwash discharge. It is desirable to have a slight amount of media discharge during backwash. You should expect to lose several inches of sand per year with proper backwashing. Although the media fills 2/3 of the tank, it makes most sense to try to keep the contamination in the top two inches of the media bed. This will allow you to quickly rinse the media during the backwash sequence. If the media contamination reaches depths below two inches, it will take a much longer backwash to rinse the media. This can also cause contamination of the under drain of your filter system. Proper backwash frequency must be determined to minimize contamination and clogged under drains.

Refer to *Table 3* for the minimum and maximum backwash flow rates. Note: if the drain is not large enough to handle the volume of water during backwash, it may be necessary to use a backwash water holding tank to buffer the backwash flow rate from the filter to the waste drain. A valve can be used to regulate the flow from the holding tank at a reduced flow rate that is suitable for the drain. Do not reduce the waste line pipe to regulate backwash flow rate as this will adversely affect the backwash cycle and cause accumulated waste in the filter vessel.

All inter-connecting piping, fitting, valves, or other accessories connected to the filter system (whether supplied by Amiad or others) must be independently supported to eliminate stress on piping. Check with local or other governmental authority to ensure compliance with applicable codes.

All Amiad SMF filter vessels have a drain plug located on the bottom.

Electrical

It is highly recommended that all electrical hook-ups to the Amiad SMF filter system be done by a qualified electrician. The control panel supplied on each SMF system will have a wiring diagram inside which references all electrical power requirements (voltage, hertz, etc.) and should be used by the electrician. If your system does not have this paperwork, please contact the factory for a copy before any further work is performed. *Table 4A & 4B* can be used as a reference for SMF pump motors, but always check and use the supplied pump motor nameplate values. These values will vary between all motor manufacturers.

Loading the Filter Media

Prior to loading media inspect laterals to determine that they are intact.

The special sand media used in Amiad SMF media filters is shipped in one half cubic foot bags and each bag weighs 50 lbs. Refer to *Table 5* for media loading quantities. Media quantity may vary with vessel pressure ratings. Correct quantities will be noted on the shipping and inspection records for each filter system.

Important! To avoid damage to the filter under-drain, the filter vessel must be filled with water (1/3 to 1/2 full) before loading media into the vessel. The under-drain support media is loaded first (**see note below**). For single applications, the silica sand is loaded next. Check filter internals for damage before loading the media.

Start-up & Operation

Initial and Seasonal Start-up

Before initial start-up or after a down period, the filter should be thoroughly inspected and cleaned.

Caution, Safety First! The first five steps in the following procedure must be performed with the electric power off, locked and tagged at the main panel. Maintenance personnel should follow the recommended safety precautions found in the Safety Precautions section in the manual prior to initial and seasonal start-up.

SMF Tanks (tanks only – no pump)

1. Loosen the access port covers and lubricate the bolts if necessary.
2. Inspect the over-drain assembly and media. If the media is contaminated, remove the foreign material or replace the media. Replace the access port and manway covers.
3. Open the air relief valve on top of the filter tank and start flow from source.
4. Differential pressure switch comes set from the factory at 16 PSI.
5. Check the voltage and current to the control panel for proper voltage and amps.
6. Check the unit for any air or water leaks. Any air leaks in the pump suction piping must be found and repaired. Failure to do so could result in poor performance and/or personal injury.
7. Backwash the filter 3-4 times initially to remove any fine grit or contaminants that may be in the media. After backwashing the filter, check the pressure gauge on top of the filter tank and record the clean media operating pressure (inlet gauge). The media should be backwashed whenever the pressure drop across the filter media reaches 16 PSI, or every 24 hours, whichever occurs first.

SMF System (tank and pump)

1. SMF filter with pre-strainers: make sure water supply to pump suction is shut off to prevent flooding. Loosen the bolts around the pump pre-strainer tank lid. Remove the lid, inspect the O-ring seal and lubricate. Remove debris from the pump pre-strainer basket. Replace the basket, lid and bolts. Open water supply shut off valve to ensure pump suction is flooded.
2. Turn the pump and motor shaft by hand to ensure free rotation.
3. Loosen the access port covers and lubricate the bolts if necessary.
4. Inspect the over-drain assembly and media. If the media is contaminated, remove the foreign material or replace the media. Replace the access port and manway covers.
5. Open the air relief valve on top of the filter tank. Start the pump motor briefly and check the arrow on the pump volute for proper rotation. Turn the pump motor off. **Do not operate the pump for an extended period of time with the pump rotating backwards!** If rotation is backward, have a qualified electrician change pump motor leads to correct rotation.
6. Differential pressure switch comes set from the factory at 16 PSI.
7. With the air relief valve open, check the isolation valves in the filter inlet and outlet water lines to verify they are open. Make sure the pump is primed. Start the pump and allow the filter vessel to fill. Close the manual air relief valve on top of the vessel after all air has been vented from the vessel.
8. Check the voltage and current of all leads on the pump motor. The current draw should not exceed the pump motor nameplate rating. Check for any unusual noise or vibrations.
9. Check the unit for any air or water leaks. Any air leaks in the pump suction piping must be found and repaired. Failure to do so could result in poor performance and/or personal injury.

10. Backwash the filter 3-4 times initially to remove any fine grit or contaminants that may be in the media. After backwashing the filter, check the pressure gauge on top of the filter tank and record the clean media operating pressure (inlet gauge). The media should be backwashed whenever the pressure drop across the filter media reaches 16 PSI, or every 24 hours, whichever occurs first.

After First Hour of Operation

1. With the filter pump running, the auto air vent releases air from top of the filter vessel. Excessive air release generally indicates a leak, which must be repaired. Air accumulation in the filter vessel can result in an unsafe condition due to the stored high energy potential of any compressed air within the vessel.
2. Again, check the unit for any unusual noise or vibration.
3. Again, check unit for any air or water leaks.

Operation

During operation, to ensure long term dependable operation, the filter should be inspected, cleaned and lubricated on a regular basis. The required service functions and recommended frequency (minimums) for each are shown in the Operating and Maintenance *Table 1*. If any problems occur, please refer to *Table 7* for *Troubleshooting Procedures*. If you have any questions, please contact the factory.

Cold Weather Operation

Amiad SMF media filters that will be exposed to below freezing ambient temperatures require protection to prevent freezing. Installation in a heated indoor space is the best means of preventing water from freezing in a filter. When indoor installation is impractical because of filter location or space limitations, supplemental heat must be supplied through the use of electrical heater tape and insulation. The parts of the filter that must be heat traced and insulated are: pump, pump pre-strainer, pump piping and valves, differential pressure switch tubing and filter vessel. The unit should be drained when it is to be shut down for any period of time. Refer to the following section, *Seasonal Shutdown*, for recommendations.

Seasonal Shutdown

The following services should be performed when the unit is to be taken out of service for an extended period of time.

1. Shut off all electrical power.
2. Close the isolation valves in the filter inlet and outlet water lines. For units using a backwash source other than the system, close the shut off valve in the line from that source also.
3. Drain all external piping to and from the filter.
4. Loosen the bolts that hold the filter vessel access covers in place and remove the cover. Lubricate the bolts if necessary. Replace the cover gaskets if necessary.
5. Inspect the over-drain assembly and media pack. If the media is contaminated, remove the foreign material and replace the filter media if necessary. Replace the filter vessel access covers and secure the bolts.

Maintenance Procedures

Refer to *Table 1* for suggested operation and maintenance schedules of Amiad SMF systems.

Pump Pre-strainer (if equipped)

Warning! Disconnect all electrical power prior to performing pump maintenance. The filter pre-strainer basket on the pump inlet must be checked regularly and kept free of debris. Failure to do so may damage the pump and/or motor. Shut off the power, close the valves, open the manual air relief valve, and remove bolts and the pre-strainer cover. Lift the basket out of the housing and remove any foreign material. Replace the basket, lubricate the O-ring, install the cover and tighten the bolts.

Backwashing

Differential pressure across the filter media progressively increases as trapped particulate accumulate in the filter media bed. On filters equipped with automatic backwash, the backwash cycle is initiated upon reaching a 16 PSI pressure differential. Since units with automatic controls perform this function as necessary, a detailed backwash procedure is only provided for manual units. However, automatic units can be manually backwashed by selecting *Flush* with the 3 position switch located on the control panel. The backwash cycle is field adjustable on most units and is factory set at two minutes. To prevent unfiltered water from “short circuiting” through the media and to extend media life, the filter should be backwashed regularly; at least once every 24-48 hours.

For manual backwash filters using a backwash water source other than the unfiltered source water (e.g. city water):

1. Shut off the electrical power to the pump motor
2. Move the handle on the linkage to position the valves in backwash mode
3. Allow the filter to backwash for approximately three minutes
4. Move the handle on the linkage to position the valves in the filtration mode
5. Re-start the pump motor

For manual control units using the system water for backwash:

1. Shut off the electrical power to the pump motor
2. Move the handle on the linkage to position the valves in the backwash mode
3. Re-start the pump motor
4. Allow the filter to backwash for approximately three minutes
5. Shut off the electrical power to the pump motor
6. Move the handle on the linkage to position the valves in filtration mode
7. Re-start the pump motor

Filter Vessel

The filter vessel internal components should be visually inspected annually or whenever backwashing does not reduce the pressure of the filter tank to the starting media gauge pressure. Remove the access port on the top of the tank to inspect the internal components.

Note: Always use care and follow proper shut-down procedures. Inspect the over-drain assembly for any debris, blockage or damage, and clean or replace if necessary. Remove and inspect the media. The SMF filters have hand hole ports located on the top of the tank for easy removal of the media and inspection of the under-drain assembly. Over a period of time, foreign matter may become embedded in the media pack that cannot be removed by backwashing. Contaminated media should be disposed of in accordance with state and federal requirements. Unscrew the under-drain laterals and inspect for blockage or damage. Clean or replace if necessary. If replacement of one or more laterals is necessary, it is recommended to replace all laterals in the under-drain. Refill the vessel with the proper amount of new media, following the procedure for media loading.

Water Treatment

Filtration is an effective way of reducing and managing the level of contamination in a fluid system. However, there are other components of equal importance in a water treatment program. For closed loop systems, often the water must often be further treated to inhibit or prevent the deposition of dissolved solids on heat transfer surfaces. As water evaporates, without proper treatment, the concentration of dissolved solids increases and will result in scale build-up on heat transfer surfaces. Additionally, water often requires treatment for the control of corrosion, bacteria (including Legionella) and other biological contaminants.

To control all potential contaminants, a comprehensive water treatment program must be developed and employed. For specific recommendations on water treatment, a water treatment professional should be consulted.

Factory Authorized Parts

Factory authorized parts are available through your Amiad representative. Please refer to *Table 6* for replacement parts. Contact the factory if assistance is required. Be sure to include the filter serial number and model when ordering parts.

To facilitate servicing the unit, it is suggested that the following spare parts be carried on hand:

1. O-ring or gasket for filter tank access port and man hole
2. O-ring seal or gasket for pump pre-strainer lid (if applicable)
3. Pump Repair Kit (mechanical seal) – for systems with pumps only

Safety Precautions

All electrical, mechanical and rotating machinery constitute a potential hazard; particularly for those not familiar with design, construction, and operation. Adequate safeguards (including use of protective enclosures, when necessary) should be taken with this equipment both to safeguard the public from injury and to prevent damage to the filtration equipment and the premises.

Filter system operation, maintenance and repair should be undertaken only by trained and qualified personnel. All such personnel should be thoroughly familiar with the equipment, the associated system and controls, and the procedures set forth in this manual. Proper care, procedures, and tools must be used in handling, lifting, installing, operating, maintaining, and repairing this equipment, to prevent personal injury and/or property damage.

For the protection of authorized service and maintenance personnel, the pump motor associated with this equipment should be installed with a lockable disconnect switch located in close proximity and within sight of the filtration system. No service work should be performed on or near the pump motors without first ensuring that the pump motor has been electrically disconnected and locked out.

The re-circulating water system may contain chemicals or biological contaminants that could be harmful if inhaled or ingested. Accordingly, personnel that may be exposed directly to the mist produced by water jets or compressed air (if these are used to clean portions or components of the filter) should wear respirators with HEPA filters, NIOSH/MSHA approved number TC-21C-142/TC-21C182.

AMIAD LIMITED WARRANTY made with respect to Products specified in invoice no.

1. This certificate applies to Amiad Products purchased by _____ ("**Purchaser**"). This limited warranty extends only to the original purchaser, and is not transferable to anyone who subsequently purchases, leases, or otherwise obtains the Product from the original purchaser.
2. Amiad hereby warrants that the Products are and will be free from defects in material and workmanship under normal use and service. Amiad warrants that it will correct manufacturing defects in the Products, in accordance with the conditions set out in this warranty.
3. This warranty is enforceable for a period of 12 months as of the date Bill of Lading or equivalent (the "**Warranty Period**").
4. In the event that during the Warranty Period the Purchaser discovers a defect in material and/or workmanship in any Product or part (the "**Defective Product**"), it shall submit a written complaint to Amiad using Amiad's standard customer complaint form. For the receipt of the customer complaint form, the submissions of the complaint or any questions please contact your customer service representative.
5. Upon written demand by Amiad the Purchaser shall return the Defective Products – or a sample thereof – to Amiad, at Amiad's cost. If the customer ships any such Product, Amiad suggests the customer package it securely and insure it for value, as Amiad assumes no liability for any loss or damage occurring during shipment. Provided however that in the event Amiad determines that the warranty does not apply to such Product, Purchaser shall promptly reimburse Amiad for such cost (including freight and customs). Any returned Product or part must be accompanied by the warranty certificate and the purchase invoice. It is clarified that the Purchaser may not return the Defective Product unless such return was coordinate and approved by Amiad in advance.
6. Amiad's obligation under this warranty shall be limited to, at its option, the repair or exchange, free of charge, of the Product or any part which may prove defective under normal use and service during the Warranty Period. The provision of a repaired or replacement Product during the Warranty Period will result in an extension of the Warranty Period by an additional period of 12 months, provided that the total accumulated Warranty Period shall in any event be no more than 18 months.
7. This warranty is valid on the condition that the Products are installed according to Amiad's instructions as expressed in Amiad's instruction manuals and according to the technical limitations as stipulated in Amiad's literature or as stated by a representative of Amiad.
8. This warranty will not apply to damaged or defective Products resulting from or related to:
9. Fire, flood, power surges or failures or any other catastrophe/and or unforeseen occurrence, such as but not limited to those for which the customers are customarily insured;
10. Fault, abuse or negligence of the customer;
11. Customer's responsibilities, including the failure of the intake water to meet the agreed standards, as set forth in a written document, approved by Amiad or improper storage.
12. Improper or unauthorized use of the Product or related parts by the customer, including the customer's failure to operate the Product in conformity with the recommendations and instructions of Amiad, as set forth in Amiad's manuals and other written materials, the operation of the Product other than by a trained and qualified operator, or improper installation of the Product by a third party not authorized by Amiad;
13. Performance by the customer of maintenance and other services other than by a trained and qualified advanced operator, or other than in conformity with the recommendations and instructions of Amiad, or other than in accordance with procedures defined in the literature supplied for Products;
14. Any alteration, modification foreign attachment to or repair of the Products, other than by Amiad or its authorized technical representatives.
15. In no event shall Amiad be liable to the customer or any third party for any damages, including indirect, special, exemplary, punitive or consequential damages, or lost profits arising out of or in connection with this warranty, or arising out of or in connection with the Product's performance or failure to perform, even if it has been advised of the possibility of such damages.
16. Amiad will be excused for failure to perform or for delay in performance hereunder if such failure or delay is due to causes beyond its reasonable control or force majeure preventing or hindering performance.
17. The limited warranty set forth herein is the only warranty given by Amiad and is provided in lieu of any other warranties created by any documentation, packaging or otherwise.

Amiad makes no warranty whatsoever in respect of accessories or parts not supplied by Amiad. In the event that Amiad is required to correct a defective product or product not covered by this warranty, it will do so solely in consideration for additional fees.

TABLE 1 – SMF Service Schedule

Service Type	Start Up	Monthly	Semi-annually	Shutdown	Annually
General inspection of condition of unit	X	X			
Drain condensate from air line to pneumatic actuator	As required				
Clean pre-strainer basket	As required				
Inspect gaskets	X		X	X	
Check pump shaft for free rotation	X		X		
Check operation of valves	X	X		X	
Check, lubricate clamp on filter tank access port				X	X
Inspect over-drain assembly & media pack	X			X	X
Check pump motor for proper rotation	X				
Check motor voltage & current	X	X	X		
Prime pump	X				
Check pressure gauge reading (top of filter)	X	X			
Check unit for unusual noise or vibration	X	X			
Check unit for leaks	X	X			
Drain filter & piping				X	

TABLE 2 - SMF Connections
(All in inches)

Filter Model	Filter Inlet	Filter Outlet	Backwash	Pump Inlet	(Optional) Pre-strainer
SMF-20	2	2	2	1.5	2.5
SMF-24	2	2	2	1.5	2.5
SMF-30	2	2	2	2.5	3
SMF-36	3	3	3	2.5	3
SMF-42	3	3	3	3	4
SMF-48	3	3	3	3	4

TABLE 3 - SMF Flow Rates

Filter Model	Filtration Flow Rate GPM / LPS	Backwash Minimum GPM / LPS	Backwash Maximum GPM / LPS
SMF-20	43 / 2.7	32 / 2	43 / 2.7
SMF-24	63 / 4.0	50 / 3.2	63 / 4.0
SMF-30	98 / 6.2	78 / 4.9	98 / 6.2
SMF-36	142 / 9.0	114 / 7.2	142 / 9.0
SMF-42	200 / 12.6	154 / 9.7	200 / 12.6
SMF-48	250 / 15.8	200 / 12.6	250 / 15.8

TABLE 4A - SMF Electrical Requirements, 60 Hz

Model	Pump HP / KW	Voltage (3 phase) 60 HZ	Full Load Current (Amps)
SMF-20	1.5 / 1.1	208, 230, 460, 575	6.6, 6.0, 3.0, 2.4
SMF-24	2 / 1.5	208, 230, 460, 575	4, 3.6, 1.8, 1.4
SMF-30, 36	3 / 2.2	208, 230, 460, 575	10.6, 9.6, 4.8, 3.9
SMF-42	5 / 3.7	208, 230, 460, 575	16.7, 15.2, 7.6, 6.1
SMF-48	7.5 / 5.6	208, 230, 460, 575	24.2, 22, 11, 9

TABLE 4B - SMF Electrical Requirements, 50 Hz

Model	Pump HP / KW	Voltage (3 phase) 50 HZ	Full Load Current Amps
SMF-20	1.5 / 1.1	380, 415	2.6, 2.6
SMF-24	2 / 1.5	380, 415	1.7, 1.6
SMF-30, 36	3 / 2.2	380, 415	3.4, 3.1
SMF-42	5 / 3.7	380, 415	5.2, 4.7
SMF-48	7.5 / 5.6	380, 415	11.5, 10.6

TABLE 5 – SMF Media Quantity

Filter Model	QTY	Media	Volume	Part number
SMF 20	4	Sand only	1/2 CU.FT. bags	210101-000003
SMF 24	5	Sand only	1/2 CU.FT. bags	210102-000004
SMF 30	8	Sand only	1/2 CU.FT. bags	210103-000003
SMF 36	10 + 9	Gravel + Sand	1/2 CU.FT. bags	210104-000003
SMF 42	15 + 12	Gravel + Sand	1/2 CU.FT. bags	210105-000003
SMF 48	16+ 18	Gravel + Sand	1/2 CU.FT. bags	210106-000003

TABLE 6A – SMF Replacement Parts

Pumps (60 Hz)		
Description	Filter Models	Part number
1-1/2 HP SCOT #51, WEG 56J SF, VN	20	720401-000608
2 HP SCOT #51, WEG 56J SF, VN	24	720401-000609
3 HP SCOT #19, HE WEG 182JM SF, BN	30	720401-000612
3 HP SCOT #19, HE WEG 182JM SF, BN	36	720401-000610
5 HP SCOT #25, HE WEG 184JM SF, BN	42	720401-000606
5 HP SCOT #25, HE WEG 184JM SF, BN	48	720401-000584
Seal kits		
SEAL KIT - FOR SCOT PUMP # 51	20,24	720401-000272
SEAL KIT - FOR SCOT PUMP # 19 + 15	30,36	720401-000269
SEAL KIT - FOR SCOT PUMP # 25	42,48	720401-000271
Auto Air Vent		
AIR VENT BRASS 1/4" FPT 150#	20-48	730108-000166
Gauge Assembly (2 required per system)		
GAUGE ASSY 2.5", 60PSI LM ASY	20-48	720301-000080
Differential Pressure Switch		
DP SWITCH ADJUSTED WITH FITTINGS	20-48	720290-000253
Timers (level I panel only)		
AB-ON DELAY 0.05S-60HR	20-48	720211-000029
AB-ONE SHOT PULSE CONTROLLED .15-3M	20-48	720211-000030

TABLE 6B - SMF Replacement Tank and Internals

Tanks		
Description	Filter Models	Part number
TANK - 20" FIBERGLASS	20	720406-000108
TANK - 24" FIBERGLASS	24	720406-000110
TANK - 30" FIBERGLASS	30	720406-000112
TANK - 36" FIBERGLASS	36	720406-000113
TANK - 42" FIBERGLASS	42	720406-000114
TANK - 48" FIBERGLASS	48	720406-000115

TABLE 6B - SMF Replacement Tank and Internals continued

Tank Lower Internals (20"-36" tanks)		
Item Letter	Description	SAP Part number
A	LATERAL 8" LONG	700106-000124
B	LATERAL 5-1/2" LONG	700190-004173
C	LATERAL 4-1/2" LONG	700106-000172
D	LATERAL 3-1/2" LONG	700106-000173
E	LATERAL CAP	700109-004174
F	LAT EXT ARM ASSY LONG	720406-000160
G	LAT EXT ARM ASSY SHORT	700106-000171
H	MANIFOLD FOR 30 AND 36 TANK	720406-000158
I	MANIFOLD FOR 20 AND 24 TANK	720406-000159

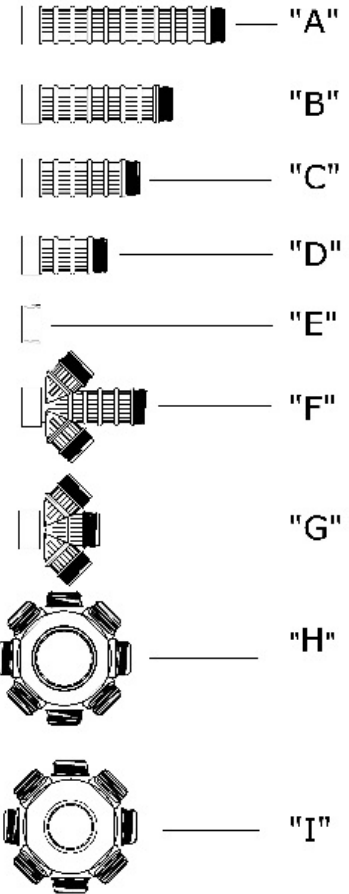

SMF 20 LOWER INTERNALS

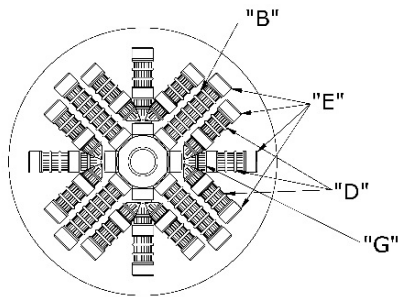

- "B" x 4 nos
- "D" x 12 nos
- "G" x 4 nos
- "E" x 16 nos

SMF 24 LOWER INTERNALS

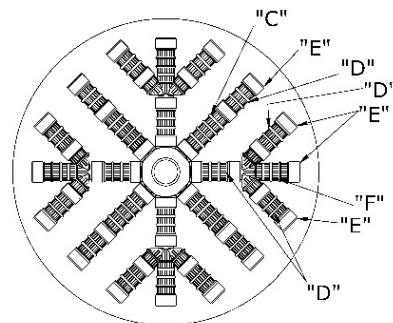

- "D" x 16 nos
- "C" x 4 nos
- "F" x 4 nos
- "E" x 16 nos

TABLE 6B - SMF Replacement Tank and Internals continued

SMF 30 LOWER INTERNALS

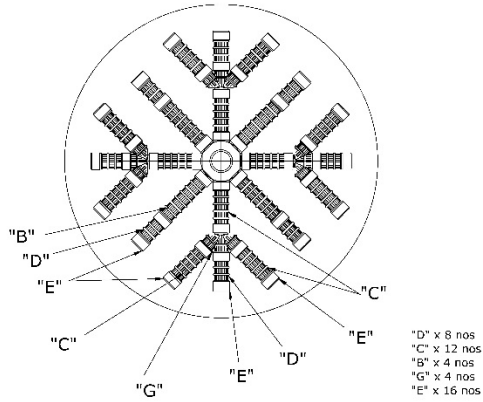

SMF 36 LOWER INTERNALS

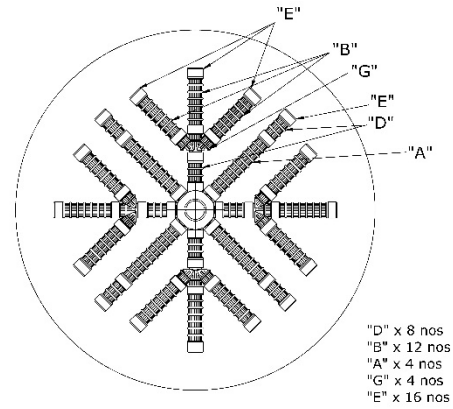

Tank Lower Internals (42"-48" tanks)		
Item Letter	Description	SAP Part number
A	LATERAL 8" LONG	700106-000124
B	MANIFOLD SOCKET	720406-000156
C	LATERAL 4-1/2" LONG	700106-000172
D	EXTENSION ARM	720406-000157
E	LATERAL CAP	700109-004174
F	DRAIN PLUG BODY	700106-000120
G	DRAIN PLUG END CAP	700106-000121

SMF 42 & 48 LOWER INTERNALS

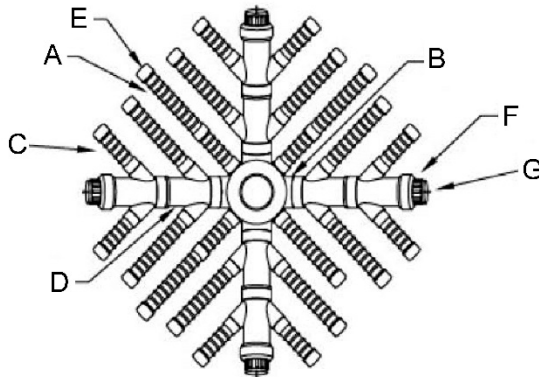
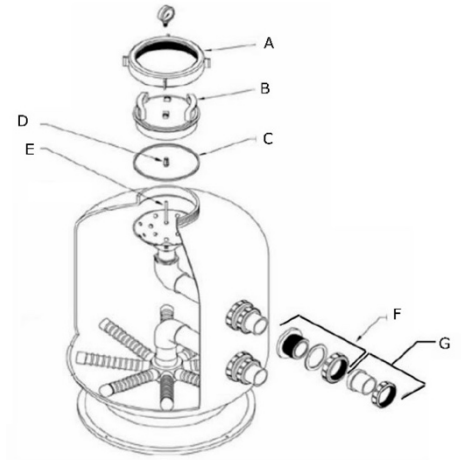

TABLE 6B - SMF Replacement Tank and Internals continued

Tank Parts (20" – 36" tanks)		
Item Letter	Description	SAP Part number
A	LOCKING RING 20-36 TANK	790210-000184
B	LID FOR 20-36 FG TANK	790210-000080
C	LID O-RING - 20-36" TANK	770101-000141
D	AIR BLEED SCREEN	700106-000106
E	AIR BLEED ASSEMBLY	700106-000107
Tank Parts (20" tanks)		
F	PORT ASSEMBLY 1 1/2" W/GSKT	700106-000193
G	1 1/2" UNION HALF W/ O-RING	700106-000181
Tank Parts (24" – 36" tanks)		
F	PORT ASSEMBLY 2" W/GSKT	700106-000023
G	2" UNION HALF W/ O-RING	700106-000145



Tank Parts (42" – 48" tanks)		
Item Letter	Description	SAP Part number
A	LID O-RING	770101-000128
B	THREADED PORT FITTING	700106-000129
C	PORT GASKET	700106-000128
D	THREADED PORT NUT	700106-000130
B+C+D	3" PORT ASSEMBLY	720406-000195
E	3" HALF UNION ASSEMBLY	700106-000146
F	DRAIN PORT ASSEMBLY	700106-000143
G (42 TANK)	LATERALS- KIT-SMF-42	780101-001031
G (48 TANK)	LATERALS- KIT-SMF-48	720406-000198
H	UPPER DISTRIBUTOR 48"	720406-000196
I	HYDRODOME DIFFUSER	720406-000197

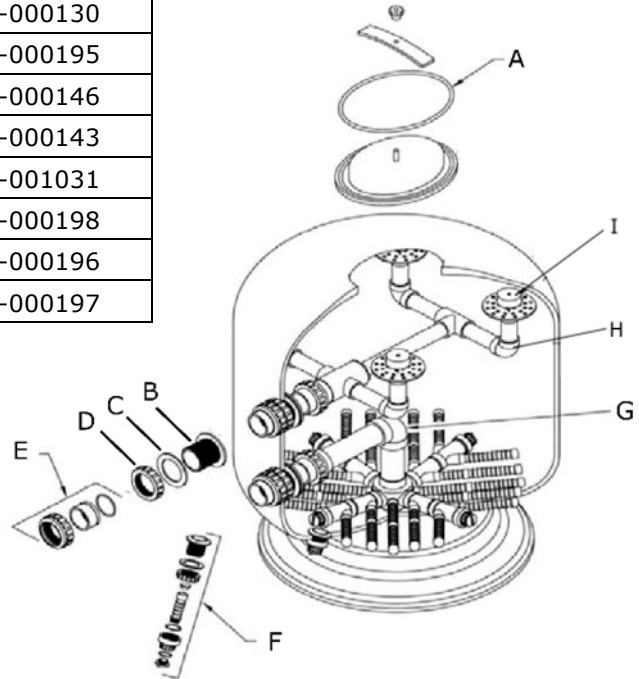

TABLE 6C - SMF Replacement Valve Parts

Item Number	Description	Filter size	SAP Part number
1	ACTUATOR, ELEC - 600LB-IN 115VAC R600	20-48	720701-000014
2	DS FOR UNITORQ R600 ACT, 0075X0175	20-48	760109-000378
3	MOUNTING PLATE - 3" X 5.5" AL	20-30	760109-000358
3	MOUNTING PLATE - 3" X 6.5" AL	36-48	760109-000357
4	BALL VALVE - 2" 3-WAY BRASS, 'KITZ'	20-30	730104-000371
4	BALL VALVE - 3" 3-WAY BRASS, KITZ	36-48	730104-000378
5	LINKAGE ASSY (does not include handles)	20-30	700106-000012
5	LINKAGE ASSY (does not include handles)	36-48	700106-000111
6	HANDLE - VALVE LEVER 2" SS304 SLAVE	20-30	760109-000370
6	HANDLE - VALVE LEVER 3" SS304 SLAVE	36-48	760109-000371
7	HANDLE - VALVE LEVER 2" SS304 DRIVE	20-30	760109-000352
7	HANDLE - VALVE LEVER 3" SS304 DRIVE	36-48	760109-000353
8	BALL VALVE - 2" 3-WAY BRASS, 'KITZ'	20-30	730104-000371
8	BALL VALVE - 3" 3-WAY BRASS, KITZ	36-48	730104-000378

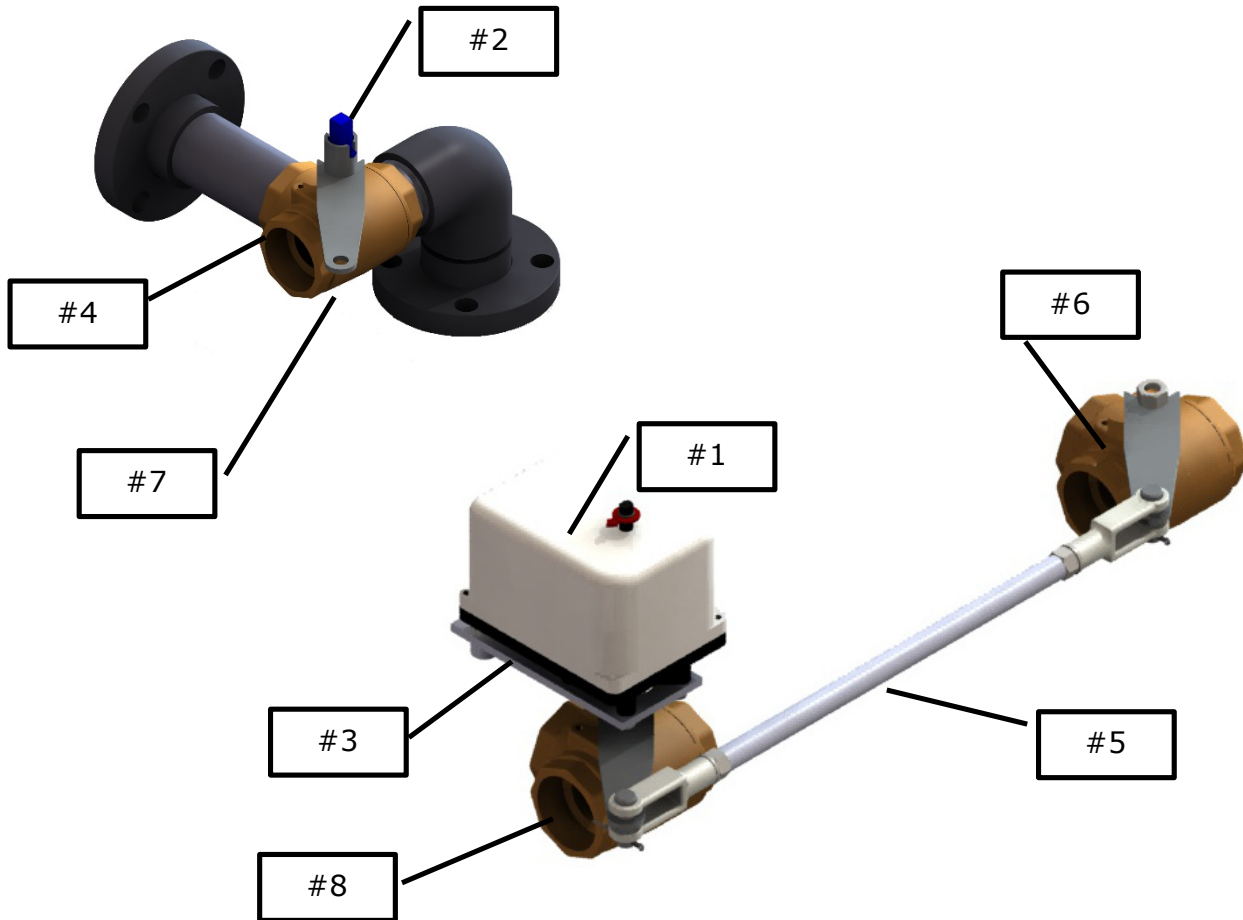

TABLE 7 – SMF Troubleshooting

<p>Increasing Frequency of Backwash Cycle</p>	<ul style="list-style-type: none"> • Backwash flow or duration is not adequate to flush filter tanks of all contaminants. • Insufficient sand volume. • Increased concentration of contaminants in water supply. 	<ol style="list-style-type: none"> 1. Adjust backwash flow or duration. 2. Add media sand to achieve proper volume. 3. Adjust backwash frequency or reduce pressure differential setting to achieve more frequent backwash cycles.
<p>Automatic Backwash Fails to Cycle</p>	<ul style="list-style-type: none"> • Controller power may be off or circuit breaker tripped. • Improper setting of differential switch. • Solenoid malfunctioning. • Loss of sufficient pressure to actuate valve(s). 	<ol style="list-style-type: none"> 1. Be sure wiring is connected correctly. Turn on power. Controller may be faulty and need replacement. 2. Adjust as necessary. 3. Check connections, clean ports and check for the sound of the solenoid actuating. Replace solenoid if necessary. 4. Check air regulator for proper adjustment. Check air lines for leaks.
<p>Media Sand Appears Downstream</p>	<ul style="list-style-type: none"> • Incorrect media sand (i.e. too fine and too small) • Broken, damaged, or missing lateral. 	<ol style="list-style-type: none"> 1. Replace media with proper sized media. 2. Repair or replace laterals of the underdrain.
<p>Backwash Valve Leaks</p>	<ul style="list-style-type: none"> • Obstruction in the valve seat. • Rubber seating is worn or damaged. • Actuator Diaphragm damaged • Linkage out of adjustment 	<ol style="list-style-type: none"> 1. Remove the obstruction. 2. Replace Valve. 3. Replace diaphragm. 4. Adjust linkage
<p>Water Hammer</p>	<ul style="list-style-type: none"> • Air in tanks. Long backwash line causing vacuum. 	<ol style="list-style-type: none"> 1. Bleed off trapped air in system. Air vent on system may be required. 2. Install vacuum breaker on backwash line.

TABLE 7 – SMF Troubleshooting Continued

<p>Pump motor runs hot</p>	<ul style="list-style-type: none"> • Motor located in direct sunlight. • Poor ventilation. • Low voltage 	<ol style="list-style-type: none"> 1. Cover motor with some type of sun shade if possible. 2. All motors require air movement for cooling. Make sure that motor has a fresh source of air for cooling. 3. Check voltage with meter.
<p>Pump will not prime (standard, not self-priming)</p>	<ul style="list-style-type: none"> • Suction line is not flooded with water. • Debris in basket strainer. • Air leaks. • Pump rotating wrong direction. 	<ol style="list-style-type: none"> 1. Check and clean out pump suction pre-strainer as required. 2. Check and clean pump pre-strainer as required. 3. Check and tighten all connections as required. 4. Check pump rotation against motor rotation arrow and rewire if necessary for proper rotation.
<p>System “Trips” when running and shuts down</p>	<ul style="list-style-type: none"> • Overload setting is too low. • Supply voltage is incorrect. • System flow is too high. • Loose Wire. 	<ol style="list-style-type: none"> 1. Check overload setting in control panel. Overload setting should be just above full load amp value on motor nameplate. 2. Check incoming supply voltage with STS system power requirements located on control panel door (outside and inside). 3. Install valve on system discharge to control flow. 4. Check all wires for loose connections.

PUMP CURVES

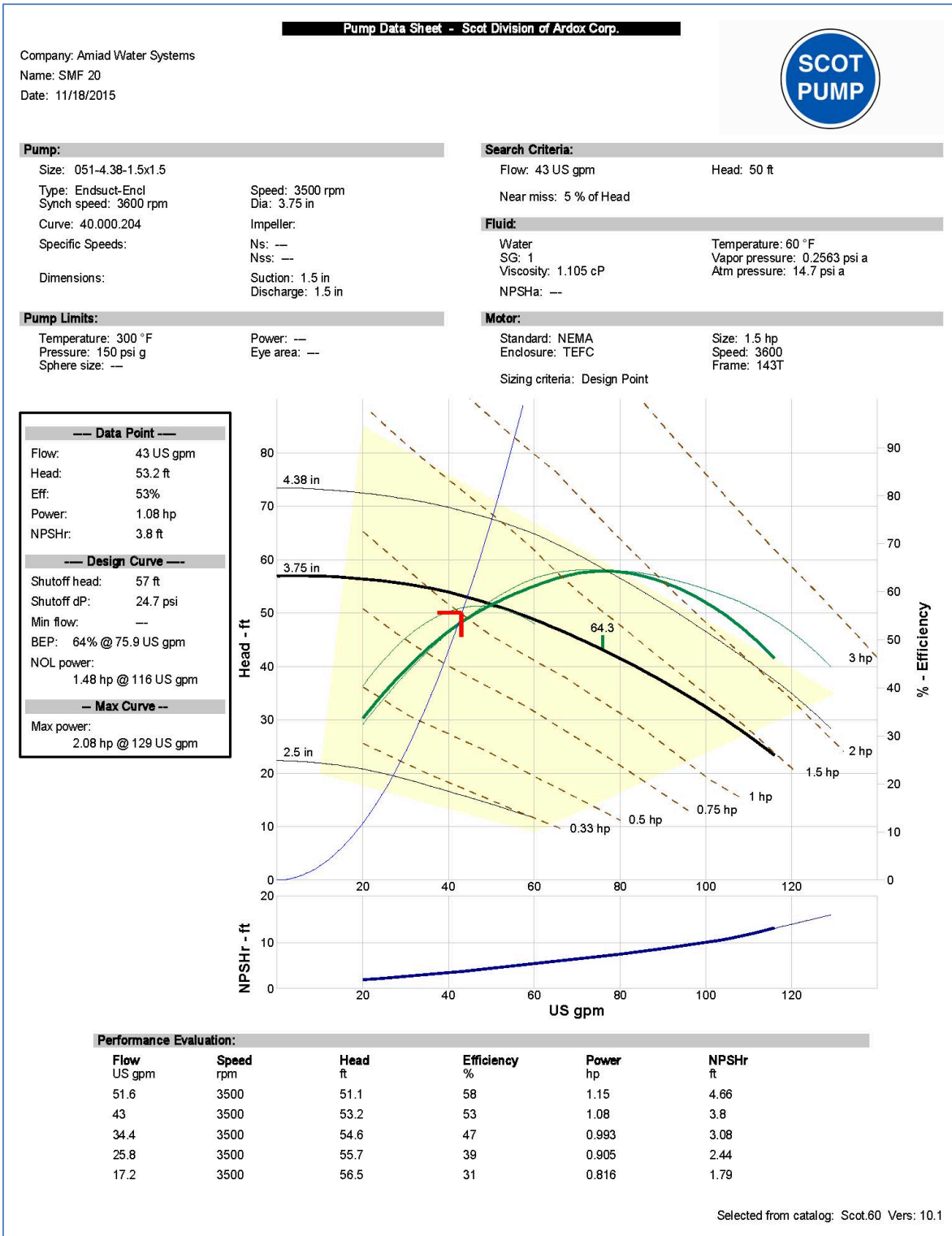

Pump Data Sheet - Scot Division of Ardox Corp.

Company: Amiad Water Systems
 Name: SMF 24
 Date: 11/18/2015



Pump:

Size: 51-4.5-1.5x1.5
 Type: Endsuct-Open
 Synch speed: 3600 rpm
 Curve: 40.000.204
 Specific Speeds:
 Dimensions:
 Speed: 3500 rpm
 Dia: 3.875 in
 Impeller:
 Ns: ---
 Nss: ---
 Suction: 1.5 in
 Discharge: 1.5 in

Search Criteria:

Flow: 63 US gpm
 Head: 50 ft
 Near miss: 5 % of Head

Fluid:

Water
 SG: 1
 Viscosity: 1.105 cP
 NPSHa: ---
 Temperature: 60 °F
 Vapor pressure: 0.2563 psi a
 Atm pressure: 14.7 psi a

Pump Limits:

Temperature: 300 °F
 Pressure: 150 psi g
 Sphere size: ---
 Power: ---
 Eye area: ---

Motor:

Standard: NEMA
 Enclosure: TEFC
 Sizing criteria: Max Power on Design Curve
 Size: 2 hp
 Speed: 3600
 Frame: 145T

--- Data Point ---	
Flow:	63 US gpm
Head:	51.6 ft
Eff:	62%
Power:	1.32 hp
NPSHr:	5.8 ft
--- Design Curve ---	
Shutoff head:	60.4 ft
Shutoff dP:	26.1 psi
Min flow:	---
BEP:	64% @ 79.8 US gpm
NOL power:	1.64 hp @ 120 US gpm
--- Max Curve ---	
Max power:	2.08 hp @ 129 US gpm

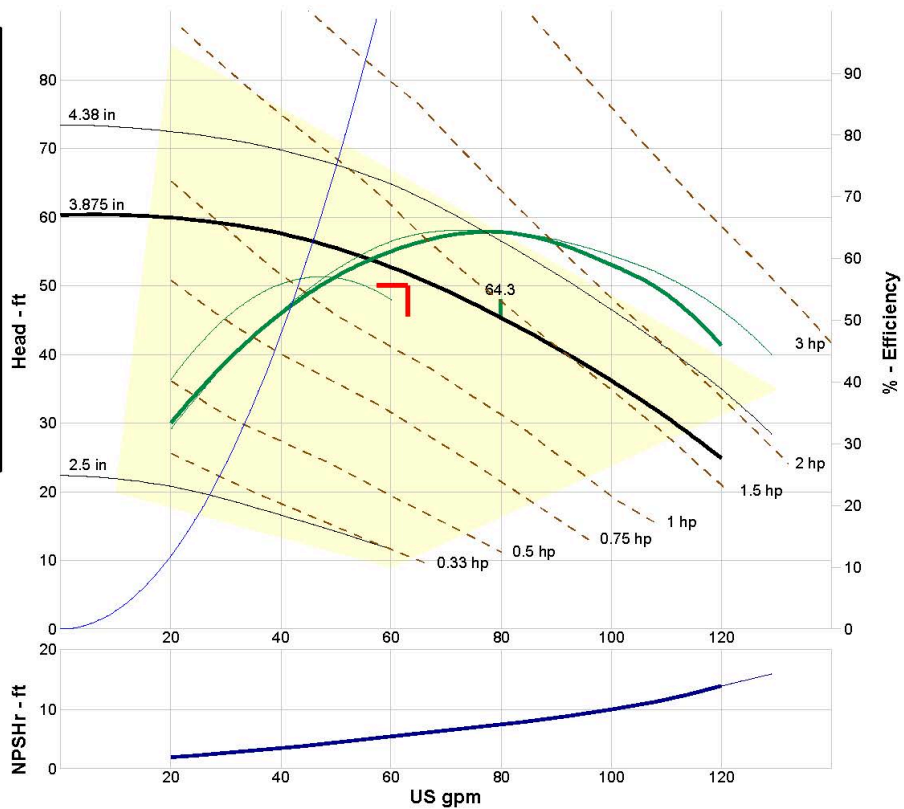

Performance Evaluation:

Flow US gpm	Speed rpm	Head ft	Efficiency %	Power hp	NPSHr ft
75.6	3500	47	64	1.4	7.06
63	3500	51.6	62	1.32	5.8
50.4	3500	55.1	56	1.22	4.54
37.8	3500	57.9	49	1.11	3.33
25.2	3500	59.4	38	0.966	2.39

Selected from catalog: Scot.60 Vers: 10.1

Pump Data Sheet - Scot Division of Ardox Corp.

Company: Amiad Water Systems
 Name: SMF 30
 Date: 11/18/2015



Pump:

Size: 19-5.6-2.5x2.0
 Type: Endsuct-Open
 Synch speed: 3600 rpm
 Curve: 40.000.112
 Specific Speeds:
 Dimensions:
 Speed: 3500 rpm
 Dia: 4.25 in
 Impeller:
 Ns: ---
 Nss: ---
 Suction: 2.5 in
 Discharge: 2 in

Search Criteria:

Flow: 98 US gpm
 Head: 50 ft
 Near miss: 5 % of Head

Fluid:

Water
 SG: 1
 Viscosity: 1.105 cP
 NPSHa: ---
 Temperature: 60 °F
 Vapor pressure: 0.2563 psi a
 Atm pressure: 14.7 psi a

Pump Limits:

Temperature: 300 °F
 Pressure: 175 psi g
 Sphere size: ---
 Power: ---
 Eye area: ---

Motor:

Standard: NEMA
 Enclosure: TEFC
 Sizing criteria: Max Power on Design Curve
 Size: 3 hp
 Speed: 3600
 Frame: 182T

--- Data Point ---	
Flow:	98 US gpm
Head:	51.7 ft
Eff:	65%
Power:	1.98 hp
NPSHr:	6.9 ft
--- Design Curve ---	
Shutoff head:	67 ft
Shutoff dP:	29 psi
Min flow:	---
BEP:	65% @ 100 US gpm
NOL power:	2.12 hp @ 140 US gpm
--- Max Curve ---	
Max power:	7.06 hp @ 200 US gpm

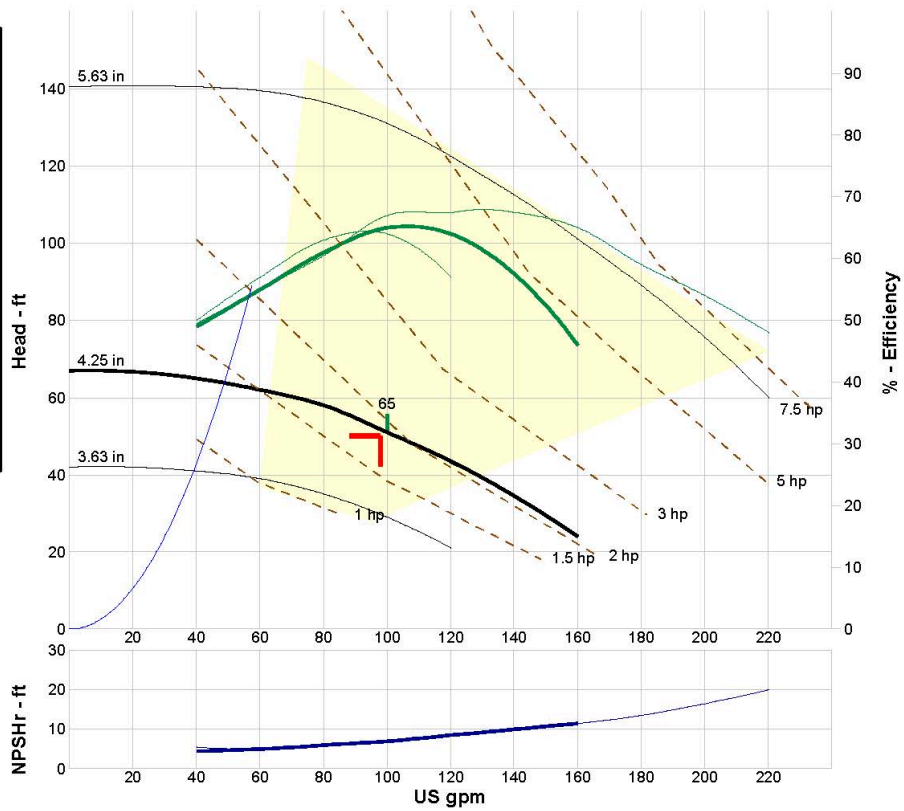

Performance Evaluation:

Flow US gpm	Speed rpm	Head ft	Efficiency %	Power hp	NPSHr ft
118	3500	44.3	64	2.05	8.35
98	3500	51.7	65	1.98	6.9
78.4	3500	58.3	61	1.9	5.92
58.8	3500	62.2	55	1.69	4.97
39.2	3500	---	---	---	---

Selected from catalog: Scot.60 Vers: 10.1

Pump Data Sheet - Scot Division of Ardox Corp.

Company: Amiad Water Systems
 Name: SMF 36
 Date: 11/18/2015



Pump:

Size: 19-5.6-2.5x2.0
 Type: Endsuct-Open
 Synch speed: 3600 rpm
 Curve: 40.000.112
 Specific Speeds:
 Dimensions:
 Suction: 2.5 in
 Discharge: 2 in

Search Criteria:

Flow: 142 US gpm
 Head: 50 ft
 Near miss: 5 % of Head

Fluid:

Water
 SG: 1
 Viscosity: 1.105 cP
 NPSHa: ---
 Temperature: 60 °F
 Vapor pressure: 0.2563 psi a
 Atm pressure: 14.7 psi a

Pump Limits:

Temperature: 300 °F
 Pressure: 175 psi g
 Sphere size: ---
 Power: ---
 Eye area: ---

Motor:

Standard: NEMA
 Enclosure: TEFC
 Size: 3 hp
 Speed: 3600
 Frame: 182T

Sizing criteria: Design Point

--- Data Point ---	
Flow:	142 US gpm
Head:	50 ft
Eff:	62%
Power:	2.85 hp
NPSHr:	10.2 ft
--- Design Curve ---	
Shutoff head:	83.7 ft
Shutoff dP:	36.2 psi
Min flow:	---
BEP:	66% @ 106 US gpm
NOL power:	2.97 hp @ 172 US gpm
--- Max Curve ---	
Max power:	7.06 hp @ 200 US gpm

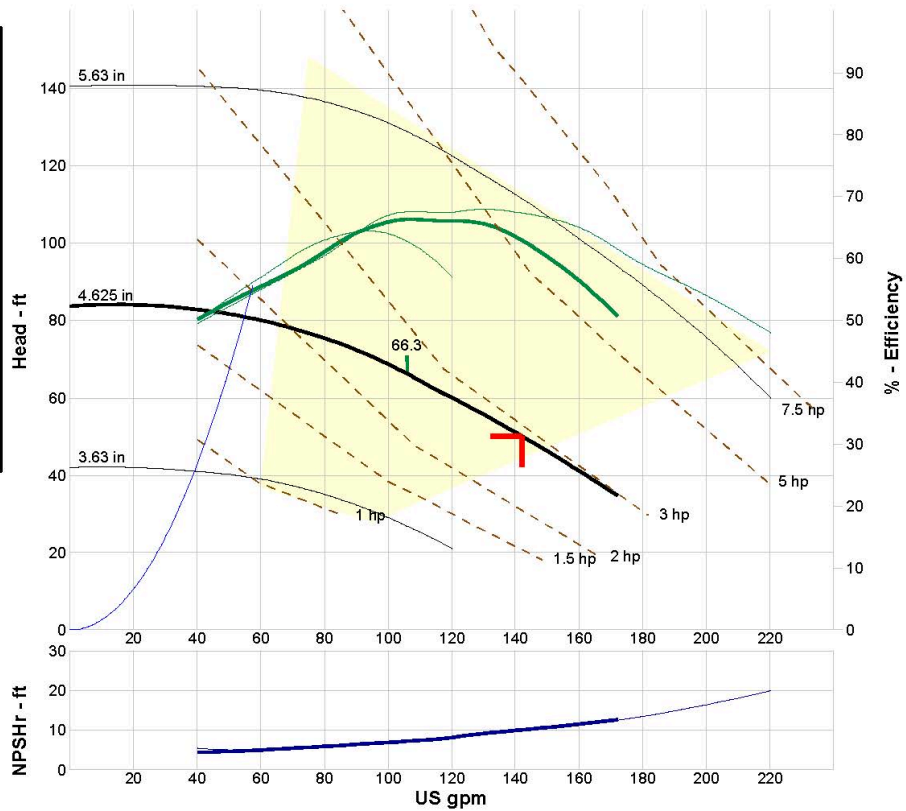

Performance Evaluation:

Flow US gpm	Speed rpm	Head ft	Efficiency %	Power hp	NPSHr ft
170	3500	35.7	52	2.96	12.5
142	3500	50	62	2.85	10.2
114	3500	62.6	66	2.72	7.78
85.2	3500	73.6	63	2.52	6.26
56.8	3500	80.4	55	2.09	4.99

Selected from catalog: Scot.60 Vers: 10.1

Pump Data Sheet - Scot Division of Ardox Corp.

Company: Amiad Water Systems
 Name: SMF 42
 Date: 11/18/2015



Pump:

Size: 25-5.6-3.0x3.0
 Type: Endsuct-Open
 Synch speed: 3600 rpm
 Curve: 40.000.444
 Specific Speeds:
 Dimensions:
 Speed: 3500 rpm
 Dia: 4.625 in
 Impeller:
 Ns: ---
 Nss: ---
 Suction: 3 in
 Discharge: 3 in

Search Criteria:

Flow: 200 US gpm
 Head: 50 ft
 Near miss: 5 % of Head

Fluid:

Water
 SG: 1
 Viscosity: 1.105 cP
 NPSHa: ---
 Temperature: 60 °F
 Vapor pressure: 0.2563 psi a
 Atm pressure: 14.7 psi a

Pump Limits:

Temperature: 300 °F
 Pressure: 175 psi g
 Sphere size: ---
 Power: ---
 Eye area: ---

Motor:

Standard: NEMA
 Enclosure: TEFC
 Sizing criteria: Design Point
 Size: 5 hp
 Speed: 3600
 Frame: 184T

--- Data Point ---	
Flow:	200 US gpm
Head:	53.8 ft
Eff:	63%
Power:	4.31 hp
NPSHr:	6.25 ft
--- Design Curve ---	
Shutoff head:	77.8 ft
Shutoff dP:	33.7 psi
Min flow:	---
BEP:	63% @ 200 US gpm
NOL power:	4.34 hp @ 250 US gpm
--- Max Curve ---	
Max power:	11.1 hp @ 400 US gpm

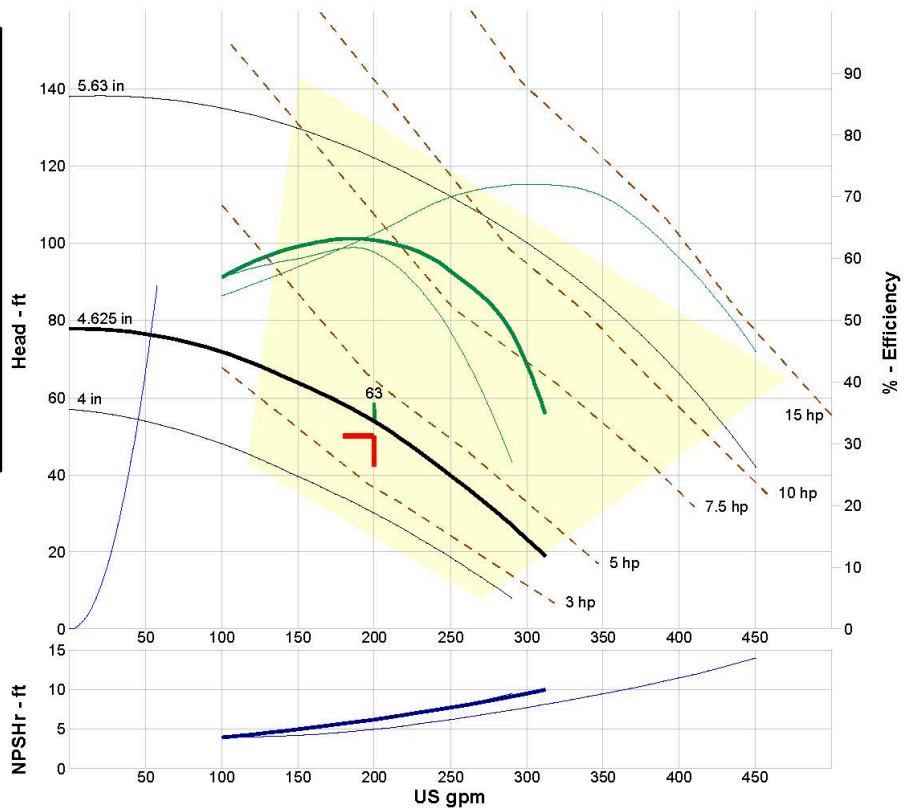

Performance Evaluation:

Flow US gpm	Speed rpm	Head ft	Efficiency %	Power hp	NPSHr ft
240	3500	42.6	59	4.33	7.45
200	3500	53.8	63	4.31	6.25
160	3500	61.8	62	3.98	5.25
120	3500	68.6	59	3.47	4.4
80	3500	---	---	---	---

Selected from catalog: Scot.60 Vers: 10.1

Pump Data Sheet - Scot Division of Ardox Corp.



Company: Amiad Water Systems
 Name: SMF 48
 Date: 11/18/2015

Pump:

Size: 25-5.6-3.0x3.0
 Type: Endsuct-Open
 Synch speed: 3600 rpm
 Curve: 40.000.444
 Specific Speeds:
 Dimensions:
 Speed: 3500 rpm
 Dia: 4.75 in
 Impeller:
 Ns: ---
 Nss: ---
 Suction: 3 in
 Discharge: 3 in

Search Criteria:

Flow: 250 US gpm
 Head: 50 ft
 Near miss: 5 % of Head

Fluid:

Water
 SG: 1
 Viscosity: 1.105 cP
 NPSHa: ---
 Temperature: 60 °F
 Vapor pressure: 0.2563 psi a
 Atm pressure: 14.7 psi a

Pump Limits:

Temperature: 300 °F
 Pressure: 175 psi g
 Sphere size: ---
 Power: ---
 Eye area: ---

Motor:

Standard: NEMA
 Enclosure: TEFC
 Sizing criteria: Design Point
 Size: 7.5 hp
 Speed: 3600
 Frame: 213T

--- Data Point ---	
Flow:	250 US gpm
Head:	53.1 ft
Eff:	63%
Power:	5.26 hp
NPSHr:	7.26 ft
--- Design Curve ---	
Shutoff head:	86.1 ft
Shutoff dP:	37.3 psi
Min flow:	---
BEP:	65% @ 216 US gpm
NOL power:	5.48 hp @ 341 US gpm
--- Max Curve ---	
Max power:	11.1 hp @ 400 US gpm

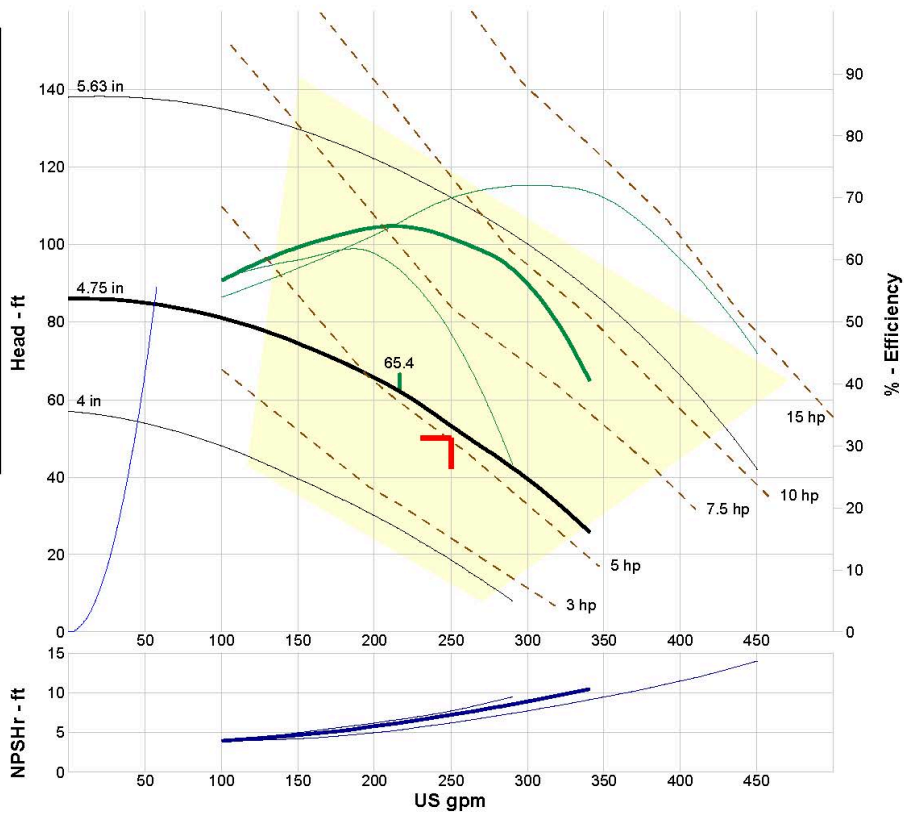

Performance Evaluation:

Flow US gpm	Speed rpm	Head ft	Efficiency %	Power hp	NPSHr ft
300	3500	38.9	54	5.35	8.97
250	3500	53.1	63	5.26	7.26
200	3500	65.2	65	5.05	5.84
150	3500	74.1	62	4.48	4.76
100	3500	81.1	57	3.61	4

Selected from catalog: Scot.60 Vers: 10.1

Level I Filter Controller Installation, Operation and Maintenance Instructions

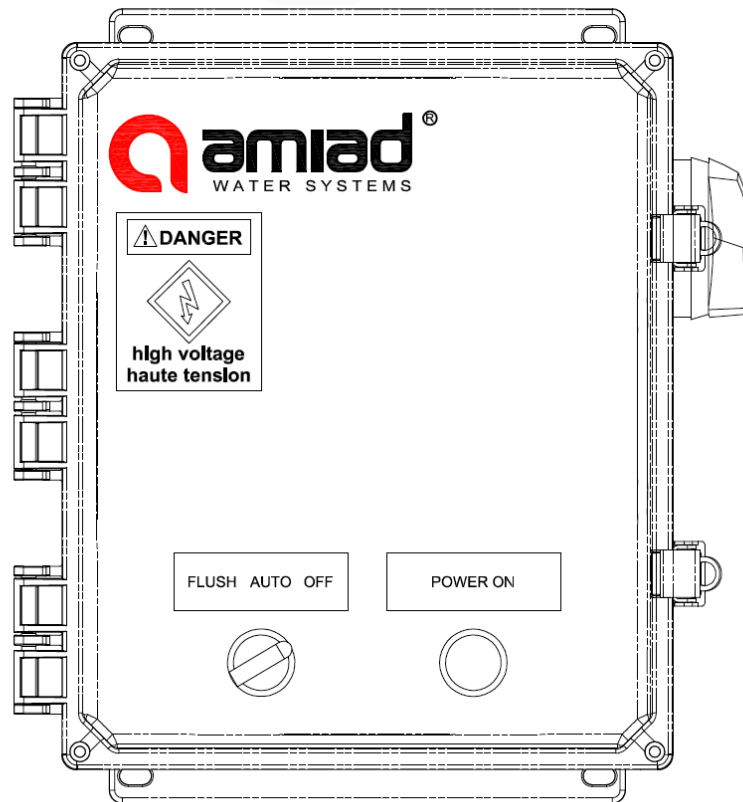

Disclaimer:

This document and the information enclosed within it contain restricted and/or privileged information that are intended only for usage by authorized Amiad technicians. If you are not a qualified Amiad technician you must not take any action in reliance on this document, unless permitted by Amiad.

None of the procedures provided in this file may be used in any form or by any means without permission from Amiad.

If you received this file in error, please notify Amiad immediately.

The confidential nature of and/or privilege in the file enclosed is not waived or lost as a result of a mistake or error in this file.

Amiad accepts no liability whatsoever, whether it was caused by:

1. Accessing or other related actions to this file.
2. Any links, procedures or materials provided/attached to this file.

Amiad assumes that all users understand risks involved within this file and/or its attached materials.

All the procedures, drawings, pictures and/or any other information provided in this document are presented as general information only; they can be altered, removed or changed without any further notice by Amiad.

This document does not replace any certified drawing, procedure or information provided by Amiad in reference to a specific customer, site or project.

All rights reserved.

Table of Contents

1. Introduction	27
2. Safety	28
2.1 Intended Use	28
2.2 Personnel Selection and Qualification	28
2.3 Informal Safety Measures	28
2.4 Hazards of Electric Power and Cables	28
2.5 Safety Devices	29
3. Product Description	29
3.1 Functional Description.....	29
3.2 Standard Component Description.....	29
Disconnect Switch	29
Contactor and Overloads	29
Transformer	30
Adjustable Flush Interval Timer	30
Adjustable Flush Duration Timer	30
3-Way Switch – “Flush-Auto-Off”	30
Power On Light	30
3.3 Transportation.....	31
3.4 Communication.....	31
4. Operation	31
4.1 Initial Operation	31
4.2 Deactivation	32
5. Electro-mechanical Controls	32

Please refer to the specific wiring diagram provided with your equipment.

1. Introduction

To Our Customers,

Thank you for your purchase from the Amiad filter product line. Amiad products are designed and built to ensure successful operation as a part of your system. If operated and maintained properly, you can expect many years of service from this equipment.

Amiad wants to be sure that this equipment meets all of your needs. We depend upon your feedback to make necessary upgrades and improvements. Please contact our office with any comments or questions.

We look forward to assisting you with this product and any future filter system needs.

Amiad Water Systems
120-J Talbert Road
 Mooresville, NC 28117
Toll Free 800 24 FILTER
Telephone 704.662.3133
Fax 704.662.3155
infousa@amiad.com

2. Safety

2.1 Intended Use

The Amiad Controller is only intended to be used with the appropriate Amiad products. Appropriate inspection and maintenance should be conducted to ensure safe operation.



Using the equipment in potentially explosive atmospheres is not permitted unless the equipment is designed for such service.

Any

- retrofitting or attachment of third party equipment
- use of spare parts that are not supplied or recommended by Amiad
- repairs implemented by companies or persons that are not authorized by the manufacturer

will result in the warranty becoming null and void.

2.2 Personnel Selection and Qualification

Persons operating or maintaining the Amiad Controller should be

- At least 18 years of age
- Properly trained for operation of this equipment
- Familiar with the relevant technical rules and safety regulations



The End-user should ensure that only personnel with the required qualifications and training shall operate and maintain the Amiad equipment.

Work on electronic components should only be performed by qualified personnel.

The term qualified personnel includes persons able to implement the required activities in each case on the basis of their vocational training and experience, as well as their knowledge of relevant and applicable standards and regulations on the prevention of accidents. These persons will be authorized by the equipment owner and by the person responsible for safety and should be trained to correctly operate and maintain this specific equipment.

2.3 Informal Safety Measures

The operating and maintenance instructions should be kept at the installation site of the Amiad Controller at all times. Applicable local regulations on the prevention of accidents and on the protection of the environment should be posted at the facility.

2.4 Hazards of Electric Power and Cables

All live components and cables are protected against accidental contact. Before opening any housing covers, connectors and cables, these items should be de-energized using safe electrical practices outlined in NFPA 79, NFPA 70 and other local standards.



2.5 Safety Devices

Trained operating personnel must ensure the following:

- Disconnect handle is damage free and able to lock out when work is required.
- Latches are secured and door is closed when equipment is in operation.



Identified deficiencies regarding these safety devices must be remedied immediately. The Amiad Controller must be disabled if any safety devices are missing or malfunctioning.

3. Product Description

This Amiad controller enables users to have powerful filter controls in a compact design. It is available in a wide array of power classes and voltages to meet the needs of the market. The initiation of the Amiad filters' self cleaning systems is by a signal from a differential pressure switch measuring the pressure of the filter inlet and outlet, a timer, control panel pushbutton for manual start or a remote start input.

The system is designed specifically for each customer's needs. Refer to the drawings/schematics or electrical data plate on the side of the enclosure to determine the largest motor which can be used and specific technical data.

3.1 Functional Description

Utilizing a start command (as described in the Product Description) for the self-cleaning cycle, the system is designed to be self-sufficient. There is no need to interfere with the filter as the equipment uses the highest level of technology to control the filter system. Typical start command is given by a differential pressure switch, however a variety of inputs are available for different applications. Consult with your local Regional Sales Manager or Application Engineer for more details on the best controller options for your application.

3.2 Standard Component Description

The following is for the standard controller configuration. Additional control options are available and may enhance the capabilities of your controller. All components are, UL approved, and conform to most international standards.

Disconnect Switch

This disconnect switch is for power isolation. It's capable of handling up to 600V AC.

Contactor and Overloads

The contactor and overload allow the end-user to have full control over the pump/drive motor. From the factory, the pump/drive motor is controlled to either turn on or off with the self-cleaning cycle as appropriate, but is easily modified to accept different logic schemes. The overloads use solid-state technology to determine if the motor is being overdriven. At the factory, these settings are set

and checked before shipment. Raising the overloads current value over the factory settings or removing the overloads from the controls will inhibit the ability of the controller to properly protect the motor. This setting should not be modified without contacting the manufacturer first.

Transformer

The transformer steps the high voltage down to a usable low voltage for the control components. It is protected with fuses on the primary side and circuit breakers on the secondary side. Exchanging the short-circuit protection of the controller should be exact one for one. Never increase the short circuit protection of the controller without consulting the manufacturer first.

Adjustable Flush Interval Timer

This timer allows the end-user to define the minimum self-cleaning cycle interval time. This is very important to ensure efficiency of the filter system. Standard factory setting is to initiate one self-cleaning cycle every day at a minimum. This is a high performance timer with 8A contacts and the ability to set the interval from 0.05 seconds to 60 hours.

Adjustable Flush Duration Timer

The self-cleaning cycle duration (when adjustable) can be adjusted through this timer. The ability to set the time as low as 0.15 seconds to 3 minutes makes this timer very versatile to satisfy the need of many different applications. This timer is started by a variety of initiation inputs. Different filter types require different time durations. Your controller should be factory set with the correct duration for your filter type. Contact the manufacturer to discuss the correct duration for your application.

Note for first-time startup:

If the self-cleaning cycle initiation signal continues to signal beyond the duration timer set-point, the next self-cleaning cycle will not be initiated until a hard reset is performed. This can be done by cycling power to the controller.

3-Way Switch – “Flush-Auto-Off”

This panel face mounted switch allows the user to locally initiate a self-cleaning cycle (“Flush”), disable the equipment/reset the self-cleaning cycle (“Off”) or to set the filter system to operate automatically (“Auto”). The “Flush” position is spring return to ensure that the self-cleaning cycle is not operated continuously.

Power On Light

This panel face LED light is for local indication that the power is on and the system is running.

3.3 Transportation

The system can only be transported with the Disconnect Switch turned to the off position, and the power isolated.

3.4 Communication

The Amiad Controller allows for basic communication using standard dry-contacts for connecting to the end-user's facility controller. Standard communication includes:

- Major Alarm dry contact
- Motor On dry contact

If the end-user requires additional logic to incorporate the filter into their system, additional inputs are available. Refer to the schematic for the following:

- Remote Start of the self-cleaning cycle – Allows the control panel to run in the Automatic mode, flush will be initiated by differential pressure or time.
- Remote Stop of the equipment - If the filter is in self-cleaning mode, it will terminate the operation, and return to filtering mode until the next self-cleaning cycle is initiated.)

4. Operation

4.1 Initial Operation

- Always use the appropriate Personal Protective Equipment (PPE) when working with electrical components.
- With the electrical source isolated, connect the appropriate electrical connections to the Amiad Controller. Check on the data plate to ensure the appropriate power supply is connected.
- Add necessary short circuit protection as required on schematic.
- Ensure pump is appropriately supplied with water.
- Ensure Stop connections are installed.
- Check the motor data plate and ensure that the motor overloads are set to the FLA on the data plate.
- Check to make sure that circuit breakers within panel are switched to the off position.
- Before switching power on to the panel, use a meter to ensure the correct voltage is being supplied to the panel.
- Close the disconnect switch to the on position to supply power to the panel.
- Before switching circuit breakers on, check voltages on the secondary of the transformer to ensure the correct voltage.
- Apply power to the control circuit by switching on the circuit breakers.
- Check configuration of Inputs and Outputs if applicable.
- Check timers to ensure appropriate flush parameters.
- Check for leaks within the filter pipes and valves and tighten if necessary as described in the filter O&M.

4.2 Deactivation

- Turn disconnect switch to the off position.
- Turn all circuit breakers to the off position.
- Apply appropriate lock-out/tag-out measures to ensure that power is not accidentally switched on.

5. Electro-mechanical Controls

Standard settings are set at the factory. These settings are specific to the customer's application. There is, however, a wide range of flexibility with this product.

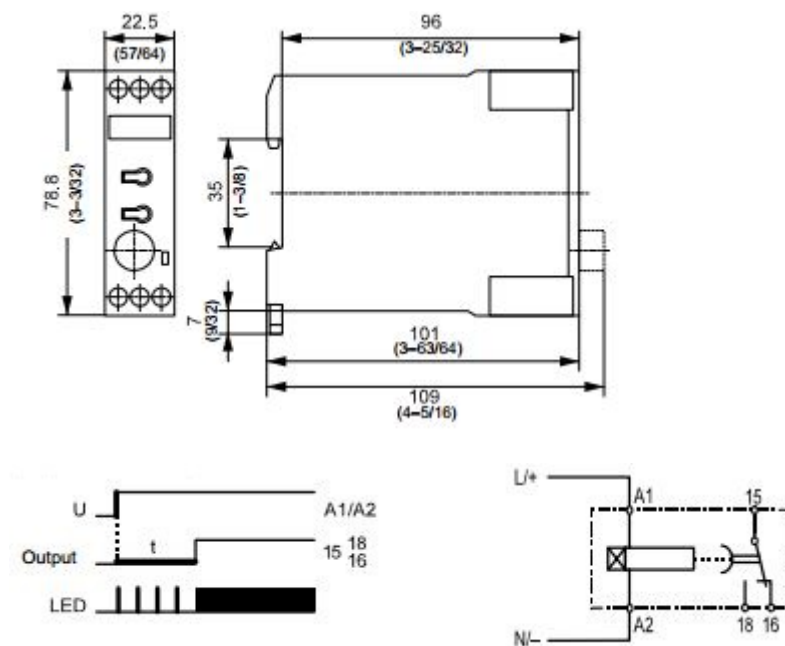

The image above is the timing chart for the Flush Interval Timer.



The image above is the timing chart for the Flush Duration Timer

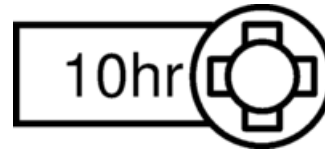

The adjustable Interval Timer has a small dial for adjusting timing settings in 12 convenient larger ranges, and a larger dial for adjusting through the specific range for both timers.

Setting the controller
Configuración del controlador
Réglage du régulateur

Large Dial number Número de marcación grande Un grand nombre de numérotation	Actual Time Tiempo real Temps réel
0.17	30s
0.33	60s
0.67	120s
1.00	180s

Set the large dial on TR1 to get the appropriate flush time.
Ajuste el dial grande en TR1 para obtener el tiempo de lavado adecuado.
Réglez le grand cadran sur TR1 pour obtenir le temps de rinçage approprié.

Small Dial Number Pequeño número de marcación Petit numéro d'appel	Large Dial number Número de marcación grande Un grand nombre de numérotation	Actual Time Tiempo real Temps réel
1h	.5	30m
1h	1.0	1h
3h	1.0	3h
10h	.8	8h
60h	.4	24h

Set the dials on TR2 to get the flush interval time.
Ajuste los selectores de TR2 para obtener el tiempo de intervalo de vaciado.
Réglez les cadrans sur TR2 pour obtenir l'intervalle de temps de chasse.

Set the overload(s) according the FLA on the motor data plate.
Establezca la sobrecarga (s) de acuerdo a la FLA en la placa de datos del motor.
Réglez la surcharge (s) selon la FLA sur la plaque signalétique du moteur.

Appendix 1 – Pump IOM



MOTORS AND DRIVES

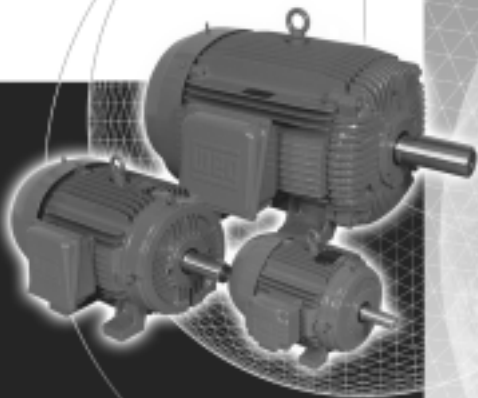

INSTALLATION AND
MAINTENANCE
INSTRUCTIONS FOR
ELECTRIC MOTORS
Frames 143/5T - 586/7T



*READ CAREFULLY THIS MANUAL BEFORE
INSTALLING THE MOTOR.*

RECEIVING CHECK

- ✓ Check if any damage has occurred during transportation.
- ✓ Check nameplate data.
- ✓ Remove shaft locking device (if any) before operating the motor.
- ✓ Turn the shaft with the hand to make sure it is turning freely.

HANDLING AND TRANSPORTATION

1 - General



*MOTORS MUST NOT BE LIFTED BY THE SHAFT,
BUT BY THE EYE BOLTS WHICH ARE PROPERLY
DESIGNED TO SUPPORT THE MOTOR WEIGHT.*

Lifting devices, when supplied, are designed only to support the motor. If the motor has two lifting devices then a double chain must be used to lift it.

Lifting and lowering must be done gently without any shocks, otherwise the bearings can get damaged.



*DURING TRANSPORTATION, MOTORS FITTED
WITH ROLLER OR ANGULAR CONTACT
BEARINGS ARE PROTECTED AGAINST BEARING
DAMAGES WITH A SHAFT LOCKING DEVICE.*



*THIS LOCKING DEVICE MUST BE USED ON ANY
FURTHER TRANSPORT OF THE MOTOR, EVEN
WHEN THIS MEANS TO UNCOUPLE THE MOTOR
FROM THE DRIVEN MACHINE.*

STORAGE

If motors are not immediately installed, they must be stored in dry places, free of dust, vibrations, gases, corrosive smokes, under constant temperature and in normal position free from other objects.

In case the motors are stored for more than two years, the bearings must be changed or the lubrication grease must be totally replaced after cleaning.

Single phase motors when kept in stock for 2 years or more must have their capacitors replaced (if any).

We recommend to turn the shaft (by hands) at least once a month, and to measure the insulation resistance before installing it, in cases of motors stored for more than 6 months or when subject to high humidity areas.

If motor is fitted with space heaters, these should be switched on.

Insulation Resistance Check

Measure the insulation resistance before operating the motor and/or when there is any sign of humidity in the winding.

The resistance measured at 25°C (77°F) must be:

$R_i > (20 \times U) / (1000 + 2P)$ [Mohm] (measured with a MEGGER at 500 V d.c.); where U = voltage (V); P = power (kW).

If the insulation resistance is less than 2 megaohms, the winding must be dried according to the following:

✓ Warm it up inside an oven at a minimum temperature of 80°C (176°F) increasing 5°C (41°F) every hour until 105°C (221°F), remaining under this temperature for at least one hour. Check if the stator insulation resistance remains constant within the accepted values. If not, stator must be reimpregnated.

INSTALLATION

1 - Safety

All personnel involved with electrical installations, either handling, lifting, operation or maintenance must be well informed and up-to-dated concerning the safety standard and principles that govern the work and carefully follow them.

We strongly recommend that these jobs are carried out by qualified personnel.



MAKE SURE THAT THE ELECTRIC MOTORS ARE SWITCHED OFF BEFORE STARTING ANY MAINTENANCE SERVICE.

Motors must be protected against accidental starts.

When performing any maintenance service, disconnect the motor from the power supply. Make sure all accessories have been switched off and disconnected.

Do not change the regulation of the protecting devices to avoid damaging.



LEAD CONNECTION IN SULATION INSIDE THE TERMINAL BOX MUST BE DONE WITH AN INSULATING MATERIAL COMPATIBLE WITH MOTOR THERMAL CLASS WHICH IS SHOWN ON THE MOTOR NAMEPLATE.

2 - Operating Conditions

Electric motors, in general, are designed for operation at an altitude of 1000m above sea level for an ambient temperature between 25°C (77°F) and 40°C (104°F). Any variation is stated on the nameplate.



COMPARE THE CURRENT, VOLTAGE, FREQUENCY, SPEED, OUTPUT AND OTHER VALUES DEMANDED BY THE APPLICATION WITH THE DATA GIVEN ON THE NAMEPLATE.

Motors supplied for hazardous locations must be installed in areas that comply with that specified on the motor nameplate.



KEEP AIR INLET AND OUTLET FREE AND CLEAN. THE AIR BLOWN OUT BY THE MOTOR SHALL NOT ENTER AGAIN. THE DISTANCE BETWEEN THE AIR INLET AND THE WALL MUST BE AROUND $\frac{1}{4}$ OF THE INLET OPENING DIAMETER.

3 - Foundation

Motors provided with feet must be installed on though foundations to avoid excessive vibrations.

The purchaser is fully responsible for the foundation.

Metal parts must be painted to avoid corrosion.

The foundation must be uniform and sufficiently tough to support any short circuit strengths. It must be designed in such a way to stop any vibration originated from resonance.

4 - Drain Holes

Make sure the drains are placed in the lower part of the motor when the mounting configuration differs from that specified on the motor purchase order.

5 - Balancing



WEG MOTORS ARE DYNAMICALLY BALANCED, WITH HALF KEY AT NO LOAD AND UNCOUPLED.

Transmission elements such as pulleys, couplings, etc must be dynamically balanced with half key before installation. Use always appropriate tools for installation and removal.

6 - Alignment



ALIGN THE SHAFT ENDS AND USE FLEXIBLE COUPLING, WHENEVER POSSIBLE.

Ensure that the motor mounting devices do not allow modifications on the alignment and further damages to the bearings.

When assembling a half-coupling, be sure to use suitable equipment and tools to protect the bearings.

Suitable assembly of half-coupling: check that clearance Y is less than 0.05mm and that the difference $X1$ to $X2$ is less than 0.05m as well.

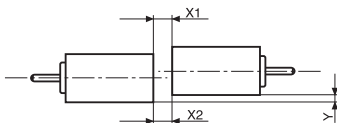

Note: The "X" dimension must be at least 3mm.

7 - Belt Drive

When using pulley or belt coupling the following must be observed:

✓ Belts must be tighten just enough to avoid slippage when running, according to the specifications stated on the belt supplier recommendation.

WARNING:

Excessive tension on the pulleys will damage the bearings and lead to a probable shaft rupture.

8 - Connection

WARNING: Voltage may be connected at standstill inside the terminal box for heating elements or direct winding heating.

WARNING: The capacitor on single-phase motors can retain a charge which appears across the motor terminals, even when the motor has reached standstill.



A WRONG CONNECTION CAN BURN THE MOTOR.

Voltage and connection are indicated on the nameplate. The acceptable voltage variation is $\pm 10\%$, the acceptable frequency variation is $\pm 5\%$ and the total acceptable variation is $\pm 10\%$.

9 - Starting Methods

The motor is rather started through direct starting. All Weg motors must be connected as shown on the motor nameplate, failure to follow the motor nameplate could lead to motor failure.

In case this is not possible, use compatible methods to the motor load and voltage.

- ✓ 3 lead single voltage and 9 lead dual voltage motors can be started as follows:
 - Full Voltage Direct On Line.
 - Auto-Transformer Starting.
 - Electronic Soft-Starting.
 - VFD Starting - subject to verification and application analysis.

- ✓ 6 lead single voltage motors and 12 lead dual voltage motors can be connected as follows:
 - Full Voltage Direct On Line.
 - WYE/DELTA Starting.
 - Auto-Transformer Starting.
 - Electronic Soft-Starting.
 - VFD Starting - subject to verification and application analysis.

The rotation direction is clockwise if the motor is viewed from DE side and if the phases are connected according to the sequence L1, L2, L3.

To change the rotation direction, interchange two of the connecting leads.



THE CONNECTION TO THE POWER SUPPLY MUST BE DONE BY QUALIFIED PERSONNEL AND WITH FULL ATTENTION TO ASSURE A SAFE AND PERMANENT CONNECTION. AFTER CONNECTING THE MOTOR, CHECK FOR ANY STRANGE BODY INSIDE THE TERMINAL BOX. THE CABLE INLETS NOT IN USE MUST BE CLOSED.

Make sure to use the correct cable dimension, based on the rated current stamped on the motor nameplate.



BEFORE ENERGIZING THE TERMINALS, CHECK IF THE EARTHING IS MADE ACCORDING TO THE ACTUAL STANDARDS. THIS IS ESSENTIAL AGAINST ACCIDENT RISKS.

When the motor is supplied with protective or monitor temperature device such as thermostats, thermistors, thermal protector, etc, connect their terminals to the corresponding devices on the control panel.

10- Start-Up



*THE KEY MUST BE FASTENED OR REMOVED
BEFORE STARTING THE MOTOR.*

a) The motor must start and operate smoothly. In case this does not occur, turn it off and check the connections and the mounting before starting it again.

b) If there is excessive vibration, check if the fastening screws are correctly fastened. Check also if the vibration comes from a neighbour machine. Periodical vibration checks must be done.

c) Run the motor under rated load for a short period of time and compare if the running current is equal to that stamped on the nameplate.

MAINTENANCE



*WARNING:
SAFETY CHECK LIST.*

1 - General Inspection

- ✓ Check the motor periodically.
- ✓ Keep the motor clean and assure free air flow.
- ✓ Check the seals or V Ring and replace them, if required.
- ✓ Check the connections as well as supporting screws.
- ✓ Check the bearings and observe:
Any excessive noise, bearing temperature and grease condition.
- ✓ When a changing, under normal conditions, is detected, check the motor and replace the required parts.
The frequency of the inspections depends on the motor type and on the application conditions.

LUBRICATION



FOLLOW THE REGREASING INTERVALS. THIS IS FUNDAMENTAL FOR PROPER MOTOR OPERATION.

1 - Machines without Grease Nipples

Motors up to frame 324/6T are normally fitted without grease nipples. In these cases the regreasing shall be done at the preventive maintenance job observing the following aspects:

- ✓ Disassemble carefully the motors.
- ✓ Take all the grease out.
- ✓ Wash the bearing with querosene or diesel.
- ✓ Regrease the bearing immediately.

2 - Machines Fitted with Grease Nipples

It is strongly recommended to grease the machine while running. This allows the grease renewal in the bearing housing. When this is not possible due to turning parts by the grease device (pulleys, bushing, etc) that offer some risk to the physical integrity of the operator, proceed as follows:

- ✓ Clean the area near to the grease nipple.
- ✓ Put approximately half of the total grease and run the motor for 1 minute at full speed. Then turn off the motor and pump the rest of the grease.
- ✓ The injection of all the grease with the motor in standstill can make the grease penetrate into the motor, through the inner seal of the bearing housing.

When regreasing, use only special bearing grease with the following properties:

RELUBRICATION INTERVALS RECOMMENDED - POLYREX® EM GREASE (ESSO/EXXON)

Frame	Amount of grease (g)	Relubrication intervals in hours - ball bearings												
		3600 rpm	3000 rpm	1800 rpm	1500 rpm	1200 rpm	1000 rpm	900 rpm	750 rpm	720 rpm	600 rpm	500 rpm		
254/6T	13	15700	18100	20000	20000	20000	20000	20000	20000	20000	20000	20000	20000	20000
284/6T	18	11500	13700	20000	20000	20000	20000	20000	20000	20000	20000	20000	20000	20000
324/6T	21	9800	11900	20000	20000	20000	20000	20000	20000	20000	20000	20000	20000	20000
364/5T	27	3600	4500	9700	11600	14200	16400	17300	19700	20000	20000	20000	20000	20000
404/5TS	27	3600	4500	9700	11600	14200	16400	17300	19700	20000	20000	20000	20000	20000
444/5TS	27	3600	4500	9700	11600	14200	16400	17300	19700	20000	20000	20000	20000	20000
504/5TS	27	3600	4500	9700	11600	14200	16400	17300	19700	20000	20000	20000	20000	20000
586/7TS	27	3600	4500	9700	11600	14200	16400	17300	19700	20000	20000	20000	20000	20000
Relubrication intervals in hours - cylindrical roller bearings														
324/5T	21	9800	11900	20000	20000	20000	20000	20000	20000	20000	20000	20000	20000	20000
364/5T	27			9700	11600	14200	16400	17300	19700	20000	20000	20000	20000	20000
404/5T	34			6000	7600	9500	11600	13800	15500	15500	15500	17800	20000	20000
444/5T	45			4700	6000	7600	9800	12200	13700	13700	13700	15700	20000	20000
447/5T	45			4700	6000	7600	9800	12200	13700	13700	13700	15700	20000	20000
504/5T	45			4700	6000	7600	9800	12200	13700	13700	13700	15700	20000	20000
586/7T	60			3300	4400	5900	7800	10700	11500	11500	11500	13400	17300	17300

WARNING:

The table above is specifically intended for relubrication with Polyrex® EM grease and bearing absolute operating temperature of:

- ✓ 70°C (158°F) for 254/6T to 324/6T frame motors;
- ✓ 85°C (185°F) for 364/5T to 586/7T frame motors.

For every 15°C (59°F) above these limits, relubrication interval must be reduced by half.

Shielded bearing (ZZ) are lubricated for bearings life as long as they operate under normal ambient conditions and temperature of 70°C(158°F).



WE RECOMMEND TO USE BALL BEARINGS FOR MOTORS DIRECTLY COUPLED TO THE LOAD.



WARNING:
EXCESS OF GREASE CAN CAUSE BEARING OVERHEATING RESULTING IN COMPLETE DAMAGE.

Compatibility of Polyrex® EM grease with other types of grease:

Containing polyurea thickener and mineral oil, the Polyrex® EM grease is compatible with other types of grease that contain:

- ✓ Lithium base or complex of lithium or polyurea and highly refined mineral oil;
- ✓ Inhibitor additive against corrosion, rust and anti-oxidant additive.

Notes:

- ✓ Although Polyrex® EM is compatible with the types of grease given above, we do not recommend to mix it with any other greases.
- ✓ If you intend to use a type of grease different than those recommended above, first contact WEG.
- ✓ On applications (with high or low temperatures, speed variation, etc), the type of grease and relubrication interval are given on an additional nameplate attached to the motor.
- ✓ Vertical mounted motors must have the relubrication intervals reduced by half.



*THE USE OF STANDARD MOTORS IN SPECIFIC
AREAS OR SPECIAL APPLICATIONS MUST BE
DONE BY CONSULT TO THE GREASE
MANUFACTURER OR WEG.*

ASSEMBLY AND DISASSEMBLY

Disassembly and assembly must be done by qualified personnel using only suitable tools and appropriated methods. The stator grips must be applied over the side face of the inner ring to be disassembled or over and adjacent part.

It is essential that the bearings disassembly and assembly be done under cleaning conditions to ensure good operation

and to avoid damages. New bearings shall only be taken out from their cases when assembling them.

Before installing a new bearing it is required to check the shaft fitting for any sharp edge or strike signals.

For bearing assembly, warm their inner parts with suitable equipment - inductive process - or use suitable tools.

SPARE PARTS

When ordering spare parts, please specify the full type designation and product code as stated on the motor nameplate.

Please also inform the motor serial number stated on the nameplate.

MOTORS FOR HAZARDOUS LOCATIONS

Besides the recommendations given previously, these ones must be also followed:



*THE SPECIFICATION OF THE MOTOR
INSTALLATION PLACE IS FOR CUSTOMER'S
RESPONSIBILITY, WHO WILL ALSO DETERMINE
THE ENVIRONMENT CHARACTERISTICS.*

Motors for hazardous locations are manufactured according to specific standards for such environments and they are certified by worldwide certifying entities.

1 - Installation

The complete installation must follow procedures given by the local legislation in effect.



THE INSTALLATION OF HAZARDOUS LOCATION MOTORS MUST BE CARRIED OUT BY SKILLED PEOPLE, AND THE THERMAL PROTECTION MUST BE ALWAYS INSTALLED, EITHER INSIDE OR OUTSIDE THE MOTOR, OPERATING AT THE RATED CURRENT.

2 - Maintenance

Maintenance must be carried out by repair shops authorized by WEG.

Repair shops and people without WEG's authorization who will perform any service on hazardous location motors will be fully responsible for such service as well as for any consequential damage.



ANY ELECTRICAL OR MECHANICAL MODIFICATION MADE ON HAZARDOUS LOCATION MOTORS WILL VOID THE CERTIFICATION.

When performing maintenance, installation or relubrication, follow these instructions:

- ✓ Check if all components are free of edges, knocks or dirt.
- ✓ Make sure all parts are in perfect conditions.
- ✓ Lubricate the surfaces of the endshield fittings with protective oil to make the assembly easier.
- ✓ Use only rubber hammer to fit the parts.
- ✓ Check for correct bolts tightening.
- ✓ Use clearance calibrator for correct T-box fitting (smaller than 0.05mm).



DO NOT REUSE DAMAGED OR WORN PARTS. REPLACE THEM BY NEW ONES SUPPLIED BY THE FACTORY.

MOTORS DRIVEN BY VFD

Applications using VFD's without filter can affect motor performance as follows:

- ✓ Lower efficiency.
- ✓ Higher vibration.
- ✓ Higher noise level.
- ✓ Higher rated current.
- ✓ Higher temperature rise.
- ✓ Reduced motor insulation.
- ✓ Reduced bearing life.

1 - Standard Motors

- ✓ Voltages lower than 440V do not require filter.
- ✓ Voltages equal or higher than 440V or lower than 575V require filter for motor power supply cables longer than 20 meters.
- ✓ Voltages equal or higher than 575V require filter for any size of power supply cables.



IF SUCH RECOMMENDATIONS ARE NOT FOLLOWED ACCORDINGLY, MOTOR WARRANTY WILL BE VOID.

2 - Inverter Duty Motors

- ✓ Check power supply voltage of the forced cooling set.
- ✓ Filters are not required.

WARRANTY TERMS SERIES AND ENGINEERING PRODUCTS

WEG warrants its products against defects in workmanship and materials for 18 months from the invoice date issued by the factory, authorized distributor or agent limited to 24 months from manufacturing date independent of installation date as long as the following items are fulfilled accordingly:

- Proper transportation, handling and storage;*
- Correct installation based on the specified ambient conditions and free of corrosive gases;*
- Operation under motor capacity limits;*
- Observation of the periodical maintenance services;*
- Repair and/or replacement effected only by personnel duly authorized in writing by WEG;*
- The failed product be available to the supplier and/or repair shop for a required period to detect the cause of the failure and corresponding repair;*
- Immediate notice by the purchaser about failures occurred and that these are accepted by WEG as manufacturing defects.*

This warranty does not include disassembly services at the purchaser facilities, transportation costs with product, tickets, accommodation and meals for technical personnel when requested by the customer. The warranty service will be only carried out at WEG Authorized Repair Shops or at WEG 's facilities.

Components whose useful life, under normal use, is shorter than the warranty period are not covered by these warranty terms.

The repair and/or replacement of parts or components, when effected by WEG and/or any WEG Authorized Repair Shop, will not give warranty extension.

This constitutes WEG 's only warranty in connection with this sale and the company will have no obligation or liability whatsoever to people, third parties, other equipment or installations, including without limitation, any claims for consequential damages or labor costs.